

MONTAGEANLEITUNG

ASSEMBLY INSTRUCTIONS

NOTICE DE MONTAGE

MONTAGEHANDLEIDING

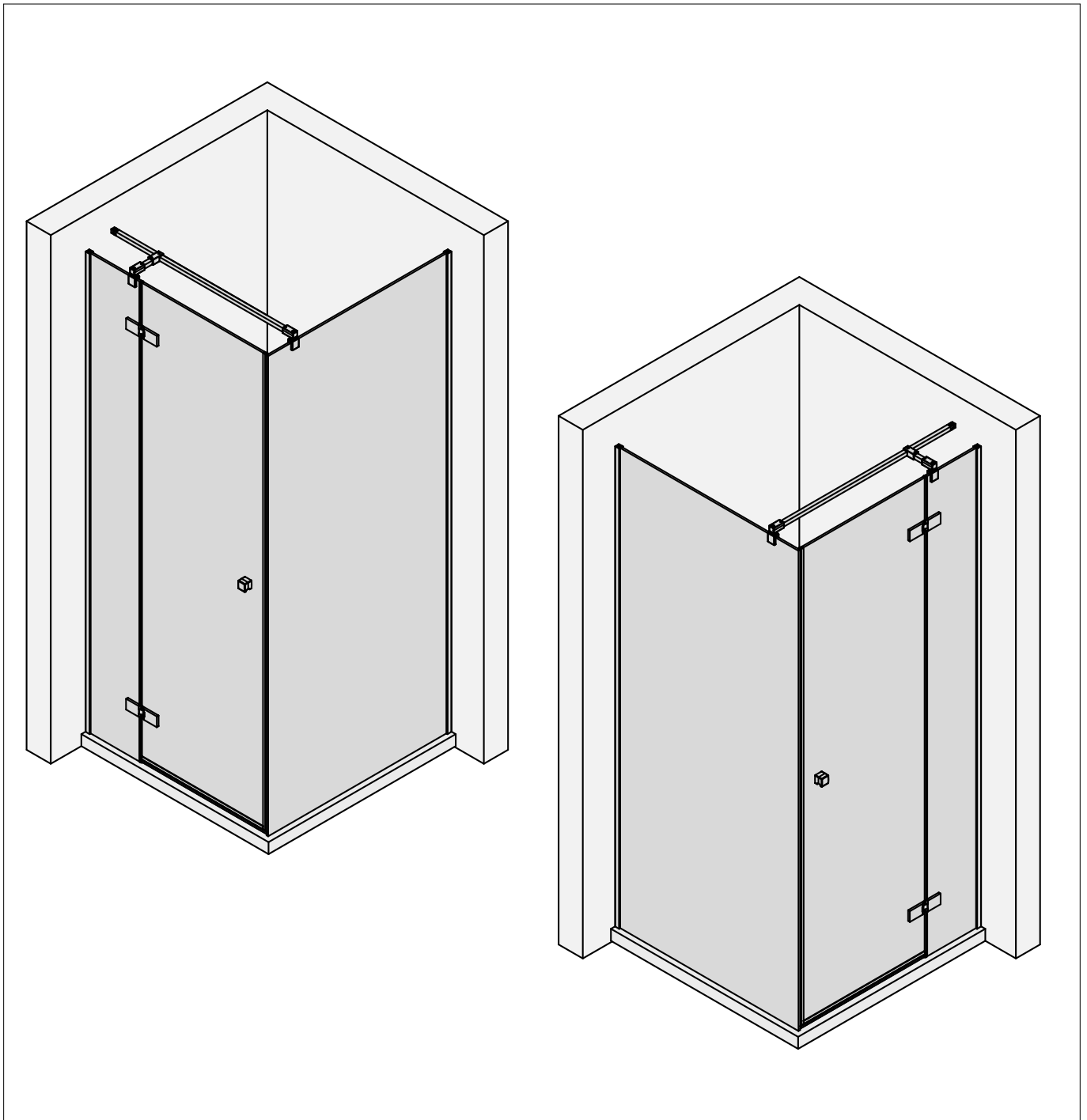



## SICHERHEITSHINWEISE / SAFETY INSTRUCTIONS CONSEILS DE SÉCURITÉ / VEILIGHEIDSAANWIJZINGEN



de Glaskanten schützen

en Protect glass edges

fr Protégez les bords du verre

nl Glasranden beschermen



de Schutzbrille tragen

en Wear safety goggles

fr Portez des lunettes de protection

nl Veiligheidsbril dragen

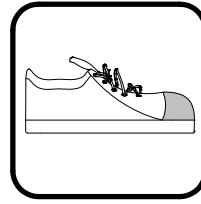

de Sicherheitsschuhe tragen

en Wear safety shoes

fr Portez des chaussures de sécurité

nl Veiligheidsschoenen dragen

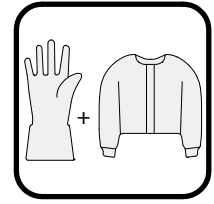

de Lange Handschuhe und langärmelige Kleidung tragen

en wear long gloves and long-sleeved clothing

fr portez des gants longs et des vêtements à manches longues

nl Draag lange handschoenen en kleding met lange mouwen

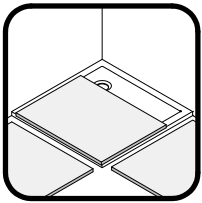

de Decken im Arbeitsbereich und dessen Umfeld auslegen

en Cover the shower tray and its area completely

fr Couvrez complètement le bac de douche et ses environs

nl Dekens op de douchebak en de omgeving leggen

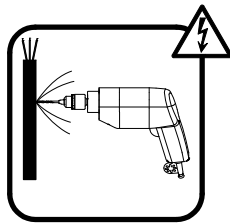

de über die Lage der Stromleitung informieren

en get information about the location of the power line

fr Informez-vous sur l'emplacement de la ligne électrique

nl Informeren over de locatie van de hoogspanningslijn

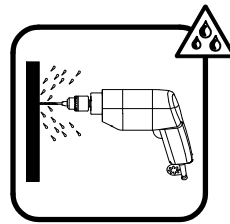

de über die Lage der Wasserleitung informieren

en get information about the location of the water pipe

fr Informez-vous sur l'emplacement de la ligne d'eau

nl Informeren over de locatie van de waterleiding

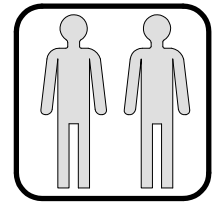

de Empfohlene Montage mit 2 Personen.

en Assembly recommended with 2 persons

fr Montage recommandé avec 2 personnes

nl Aanbevolen montage met 2 personen

## HINWEIS / NOTE / NOTE / NOOT

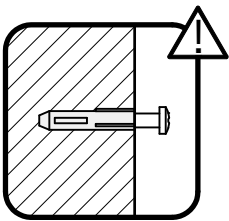

de Vor der Montage die Beschaffenheit des Mauerwerks überprüfen. Gegebenenfalls ist das im Lieferumfang enthaltene Befestigungsmaterial nicht für die Befestigung geeignet.

en Check the condition of the masonry before installation. If applicable, the fixing material included in the scope of delivery is not suitable for mounting.

fr Vérifiez l'état de la maçonnerie avant le montage. Le cas échéant, le matériel d'approvisionnement compris dans la livraison n'est pas adapté à la fixation.

nl Controleer de toestand van het metselwerk voor de installatie. Indien gewenst is het bij de levering inbegrepen bevestigingsmateriaal niet geschikt voor montage.

de Die Aufstellfläche der Duschkabine muss eben sein.

en The installation surface of the shower enclosure must be level.

fr La surface d'installation de la cabine de douche doit être plane.

nl Het montagevlak van de douchewand moet waterpas zijn.

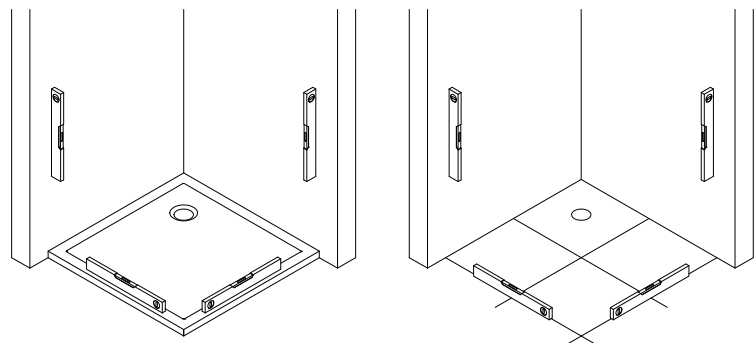

## AUFBAUART / ASSEMBLY SITUATION / TYPE DE MONTAGE / ASSEMBLAGE SITUATIE

- de** Bei der Montage der Duschkabine gibt es zwei Aufbauarten: Aufbau **a** und **b**  
In dieser Montageanleitung wird der Aufbau **a** dargestellt. Die Montageschritte für den Aufbau **b** sind spiegelbildlich durchzuführen.
- en** There are two types of installation for the shower enclosure: **a** and **b**  
Situation **a** is described in this assembly instruction. The assembly steps for situation **b** must be carried out in mirror image.
- fr** Il y a 2 possibilités de monter la paroi de douche : **a** et **b**  
La version **a** est illustrée dans la notice de montage. Les étapes pour monter la version **b** sont inversées.
- nl** Er zijn twee soorten installatie voor de douchewand: **a** en **b**  
Montage **a** wordt getoond in deze montagehandleiding. De montageschappen voor installatie **b** moeten in spiegelbeeld worden uitgevoerd.

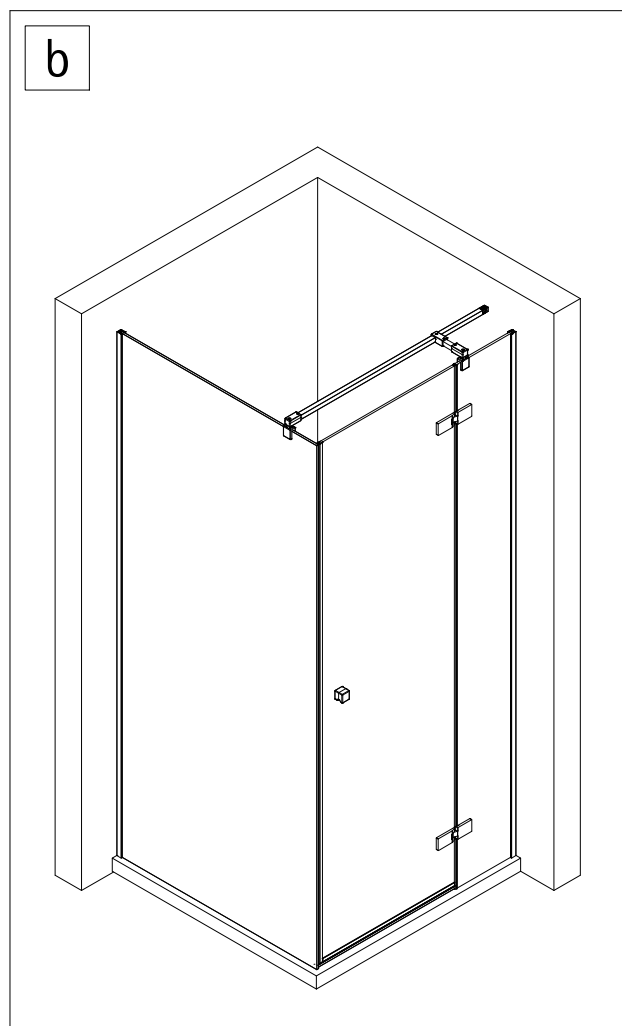
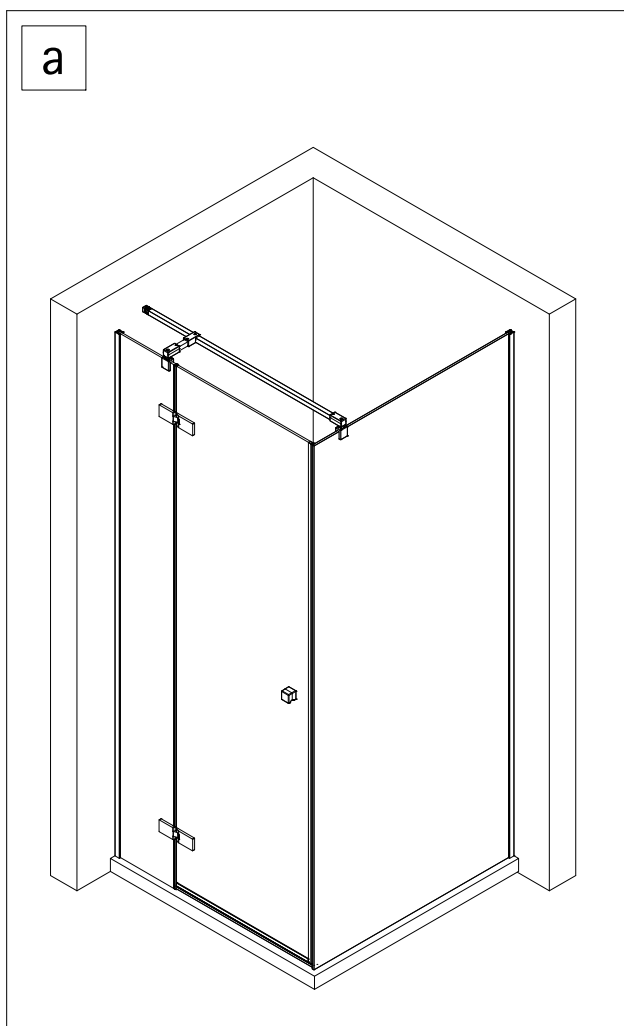

## MAßE / DIMENSIONS / DIMENSIONS / AFMETINGEN

- de** Prüfen, ob die gemessenen Maße innerhalb der Tabellenwerte (A, B bzw. C, D) liegen, damit die Duschkabine problemlos, anhand der Montageanleitung aufgebaut werden kann.
- en** Check whether the measured dimensions are within the table values (A, B or C, D), so that the shower enclosure can be assembled without any problems using the assembly instructions.
- fr** Vérifier que les dimensions mesurées se situent dans les valeurs du tableau (A, B ou C, D), afin que la cabine de douche puisse être montée sans problèmes en suivant les instructions de montage.
- nl** Controleer of de gemeten afmetingen binnen de tabelwaarden (A, B of C, D) vallen, zodat de douchewand zonder problemen met behulp van de montagehandleiding kan worden gemonteerd.

### de Montage auf Duschwanne

(Maße des installierten Duschbeckens)

### en Mounting on shower tray

(Dimensions of the installed tray)

### fr Montage sur receveur de douche

(Dimensions du mur au bord d'extérieur du receveur)

### nl Montage op douchebak

(Afmetingen van de ingebouwde douchebak)

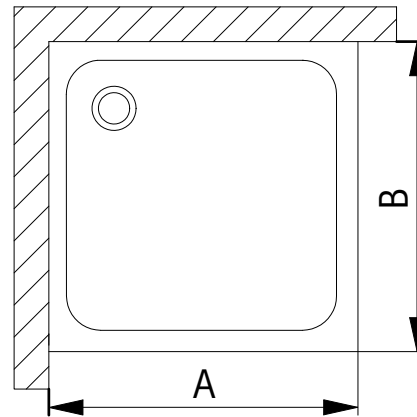

Duschwanne / shower tray receveur de douche / douchebak	A (Türseite / door side / côté porte / deur zijde)	B (Seitenwandseite / side of side panel / côté paroi / zijwand zijde)
800 mm	795 - 805 mm	795 - 805 mm
900 mm	895 - 905 mm	895 - 905 mm
1000 mm	995 - 1005 mm	995 - 1005 mm
1200 mm	1195 - 1205 mm	

oder / or / ou / of

### de Montage ohne Duschwanne

(Abmessungen des Produktes) (Glasmitte)

### en Mounting without shower tray

(Mounting on tile) (Middle of the glass)

### fr Montage sans receveur de douche

(Montage sur carrelage) (Dimension mi-verre)

### nl Montage zonder douchebak

(Montage op tegel) (midden van het glas)

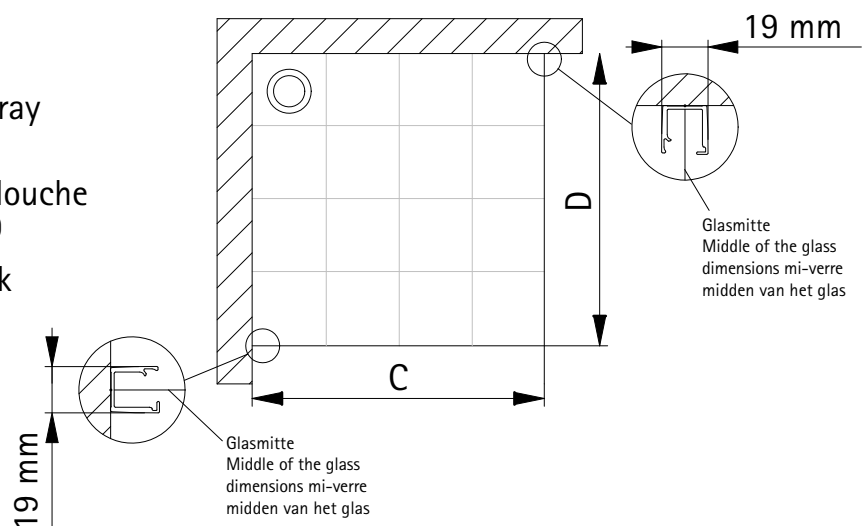

Version / Versie	C (Tür / door / porte / deur)	D (Seitenwand / side panel / paroi latérale / zijwand)
800 mm	766 - 776 mm	766 - 776 mm
900 mm	866 - 876 mm	866 - 876 mm
1000 mm	966 - 976 mm	966 - 976 mm
1200 mm	1166 - 1176 mm	

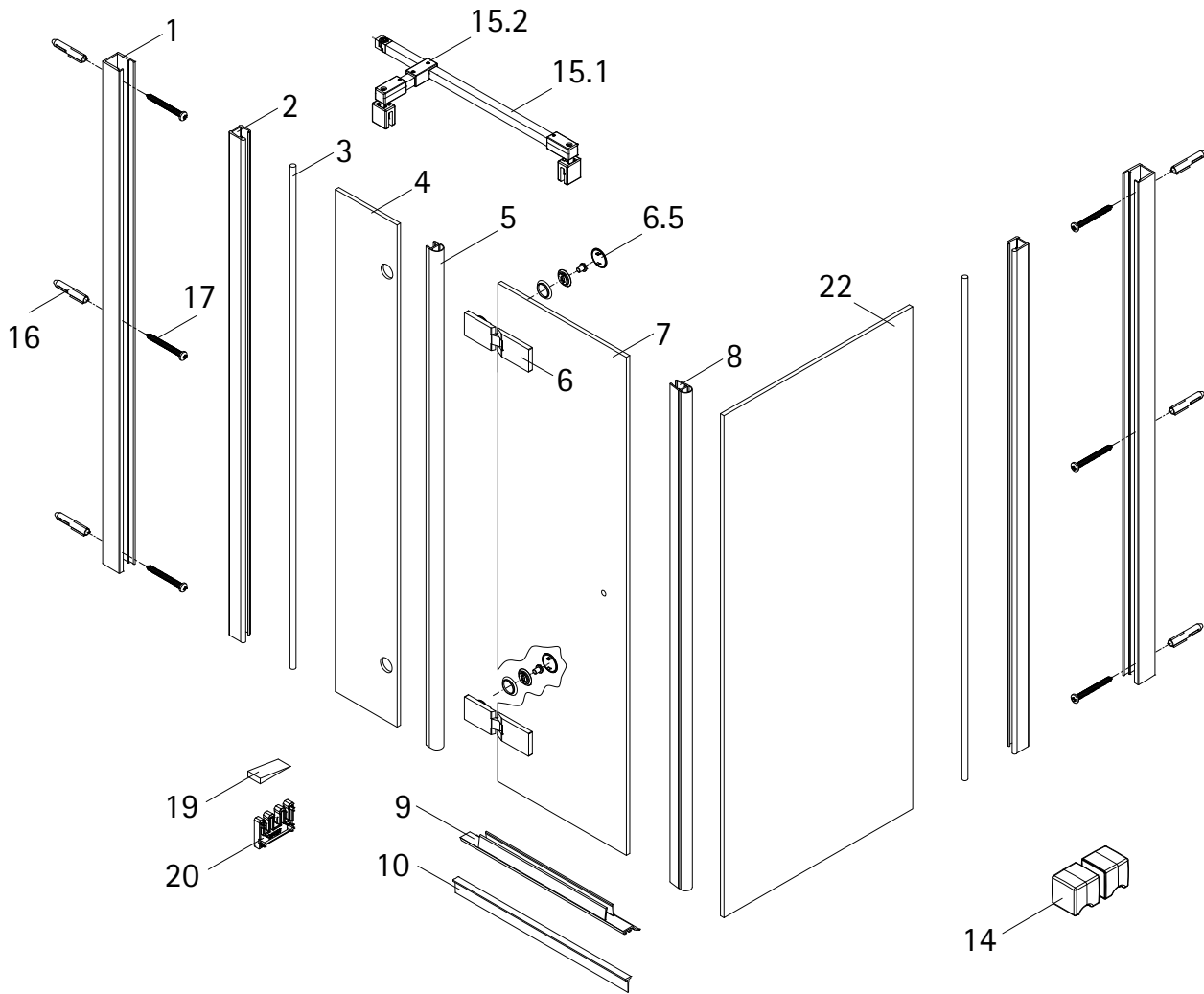

Pos.	Bezeichnung	Ersatzteil-Nr.	Preis	Pos.	Bezeichnung	Ersatzteil-Nr.	Preis
1#	2x Wandanschlussprofil	E100242-8	Stück 156,20 €	10	1x Einschubdichtung	E100067-145-10	Stück 15,70 €
1#	1x Wandanschlussprofil (Sonderfarbe)	E100242-8	Stück 254,00 €	14	1x Knopfgriff mit Griffmulde	E100140-54	Stück 55,50 €
2	2x Klemm-Dichtprofil (inkl. Pos. 3)	E100243-8	Set 57,60 €	15.1#	1x Stabilisationsbügel komplett	E100340	Stück 69,20 €
3	2x Silikonschnurdichtung			15.1#	1x Stabilisationsbügel komplett (Sonderfarbe)	E100340	Stück 129,00 €
4	1x Nebenteilscheibe			15.2#	1x Kreuzverstrebung	E100342	Stück 59,70 €
5	1x O-Dichtung vertikal (2100 mm)	E100078-8-3-1	Stück 31,40 €	15.2#	1x Kreuzverstrebung (Sonderfarbe)	E100342	Stück 116,95 €
6#	2x Pendelscharnier komplett	E100290-58	Stück 194,90 €	16	6x Dübel S6		
6#	2x Pendelscharnier komplett (Sonderfarbe)	E100290-58	Stück 341,00 €	17	6x Senkblechschraube 4,2 x 45mm		
6.5	2x Abdeckkappe			19	1x Silikonkeile (6 Stück)	E100203	Set 17,80 €
7	1x Türscheibe			20	2x Montagehilfe	E100201	Set 12,60 €
8	1x O-Dichtung, lang	E100078-8-3	Stück 26,10 €	22	1x Seitenwand		
9	1x Wasserabweisprofil	E100058-8	Stück 24,10 €				
					* Montagezubehör	E74200-2	17,80 €
					# optional		

de Geben Sie bei farbigen Ersatzteilen den Farbcode mit an: 41 - chrom | 68 - schwarz | 70 - weiß matt | 90 - edelstahl look | 280 - gunmetal gebürstet | 283 - gold matt | 285 - kupfer matt

en							
Pos.	Description	part no	price	Pos.	Description	part no	price
1#	2x wall connection profile	E100242-8	piece 156,20 €	10	1x pull-in sealing	E100067-145-10	piece 15,70 €
1#	2x wall connection profile	E100242-8	piece 254,00 €	14	1x handle complete	E100140-54	piece 55,50 €
2	2x clamping profile	E100243-8	set 57,60 €	15.1#	1x stabilizing bar	E100340	piece 69,20 €
3	2x silicone cord sealing			15.1#	1x stabilizing bar	E100340	piece 129,00 €
4	1x fixed panel			15.2#	1x stabilizing bar	E100342	piece 59,70 €
5	1x sealing strip	E100078-8-3-1	piece 31,40 €	15.2#	1x stabilizing bar	E100342	piece 116,95 €
6#	2x hinge complete	E100290-58	piece 194,90 €	16	6x dowel S6		
6#	2x hinge complete	E100290-58	piece 341,00 €	17	6x screw 4,2 x 45 mm		
6.5	2x cover caps			19	1x silicone wedges (6 piece)	E100203	set 17,80 €
7	1x door			20	2x assembly aid	E100201	set 12,60 €
8	1x sealing strip long	E100078-8-3	piece 26,10 €	22	1x side panel		
9	1x water-repellent profile	E100058-8	piece 24,10 €				
					* mounting equipment	E74200-2	17,80 €
					# optional		

en Please state the colour code for coloured spare parts: 41 - chrome | 68 - black | 70 white matt | 90 - stainless steel | 280 - brushed gunmetal | 283 - gold matt | 285 - copper matt

fr							
Pos.	Description	N° pièce détachée	prix	Pos.	Description	N° pièce détachée	prix
1#	2x profilé mural de fixation	E100242-8	pièce 156,20 €	10	1x joint silicone à lèvres souple	E100067-145-10	pièce 15,70 €
1#	2x profilé mural de fixation	E100242-8	pièce 254,00 €	14	1x poignée complète	E100140-54	pièce 55,50 €
2	2x profilé de pincement	E100243-8	set 57,60 €	15.1#	1x barre de stabilisation	E100340	pièce 69,20 €
3	2x joint de cordon en silicone			15.1#	1x barre de stabilisation	E100340	pièce 129,00 €
4	1x partie fixe			15.2#	1x barre de stabilisation	E100342	pièce 59,70 €
5	1x profilé d'étanchéité	E100078-8-3-1	pièce 31,40 €	15.2#	1x barre de stabilisation	E100342	pièce 116,95 €
6#	2x charnière complète	E100290-58	pièce 194,90 €	16	6x cheville S6		
6#	2x charnière complète	E100290-58	pièce 341,00 €	17	6x vis 4,2 x 45 mm		
6.5	2x cache			19	1x cale de silicone (6 unités)	E100203	set 17,80 €
7	1x porte			20	2x kit de montage	E100201	set 12,60 €
8	1x profilé d'étanchéité	E100078-8-3	pièce 26,10 €	22	1x paroi latérale		
9	1x joint d'étanchéité horizontal bas	E100058-8	pièce 24,10 €				
					* accessoires de montage	E74200-2	17,80 €
					# en option		

fr Veuillez indiquer le code couleur pour les pièces de rechange colorées : 41 - chromé | 68 - noir | 70 - blanc mat | 90 - acier inoxydable | 280 - gunmetal brossé | 283 - or mat | 285 - brossé mat

nl							
Pos.	Omschrijving	Onderdeel nr.	Prijs	Pos.	Omschrijving	Onderdeel nr.	Prijs
1#	2x wandansluitprofiel	E100242-8	stuk 156,20 €	10	1x inschuifdichting	E100067-145-10	stuk 15,70 €
1#	2x wandansluitprofiel	E100242-8	stuk 254,00 €	14	1x greep compleet	E100140-54	stuk 55,50 €
2	2x klemprofiel	E100243-8	set 57,60 €	15.1#	1x stabilisatie stang	E100340	stuk 69,20 €
3	2x siliconen koordafdichting			15.1#	1x stabilisatie stang	E100340	stuk 129,00 €
4	1x zijdeel			15.2#	1x stabilisatie stang	E100342	stuk 59,70 €
5	1x afdichtingsprofiel	E100078-8-3-1	stuk 31,40 €	15.2#	1x stabilisatie stang	E100342	stuk 116,95 €
6#	2x scharnier compleet	E100290-58	stuk 194,90 €	16	6x plug S6		
6#	2x scharnier compleet	E100290-58	stuk 341,00 €	17	6x schroef 4,2 x 45 mm		
6.5	2x afdekkapjes			19	1x silicone keggen (6 stuk)	E100203	set 17,80 €
7	1x deur			20	2x kit de montage	E100201	set 12,60 €
8	1x afdichtingsprofiel lang	E100078-8-3	stuk 26,10 €	22	1x zijwand		
9	1x waterdorpelprofiel	E100058-8	stuk 24,10 €				
					* montageonderdelen	E74200-2	17,80 €
					# optioneel		

nl Gelieve de kleurcode voor gekleurde onderdelen te vermelden: 41 - chroom | 68 - zwart | 70 wit mat | 90 - roestvrij staal | 280 - brons geborsteld | 283 - goud mat | 285 - koper mat

BENÖTIGTES WERKZEUG / TOOLS NEEDED  
OUTILLAGE NÉCESSAIRE / BENODIGD WERKTUIG

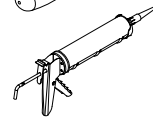
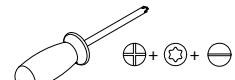
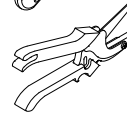
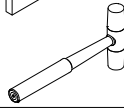
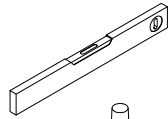
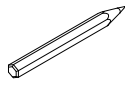
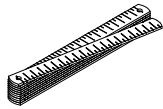
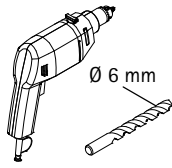

MONTAGE / ASSEMBLY / ASSEMBLAGE / ASSEMBLAGE

1

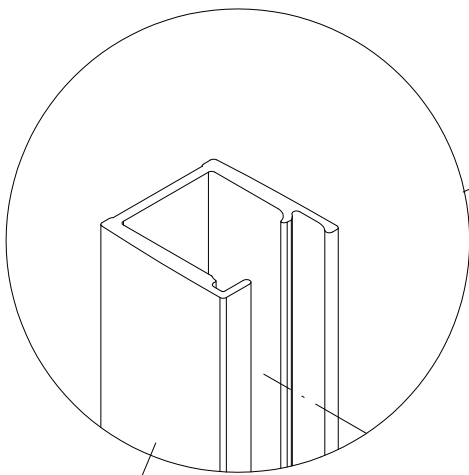

Pos. 1

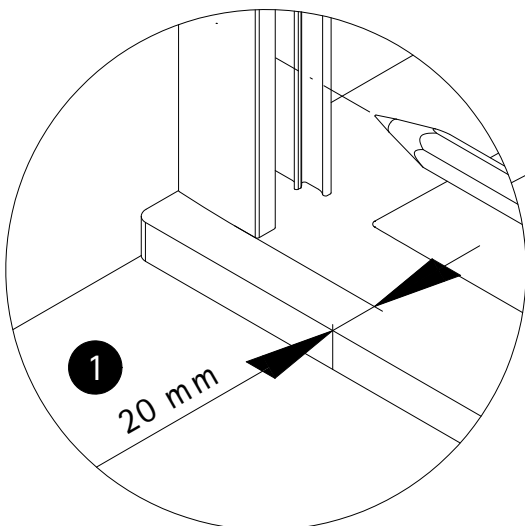
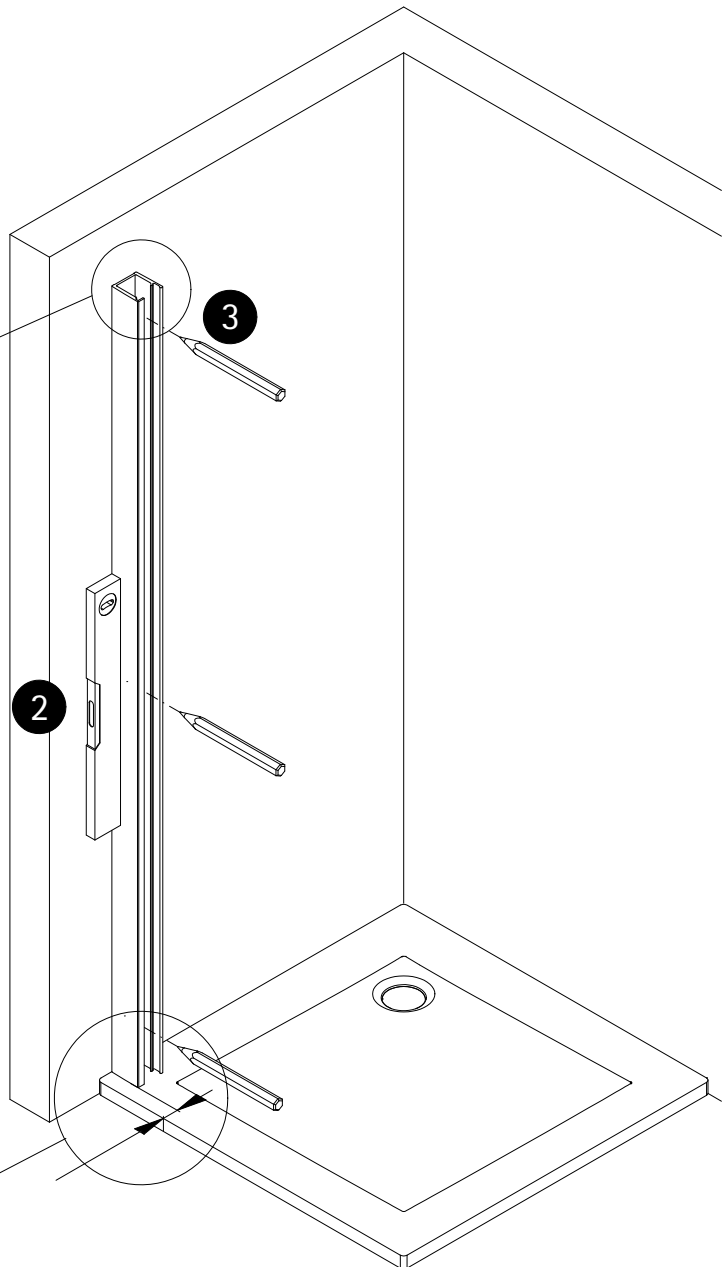

1  
20 mm

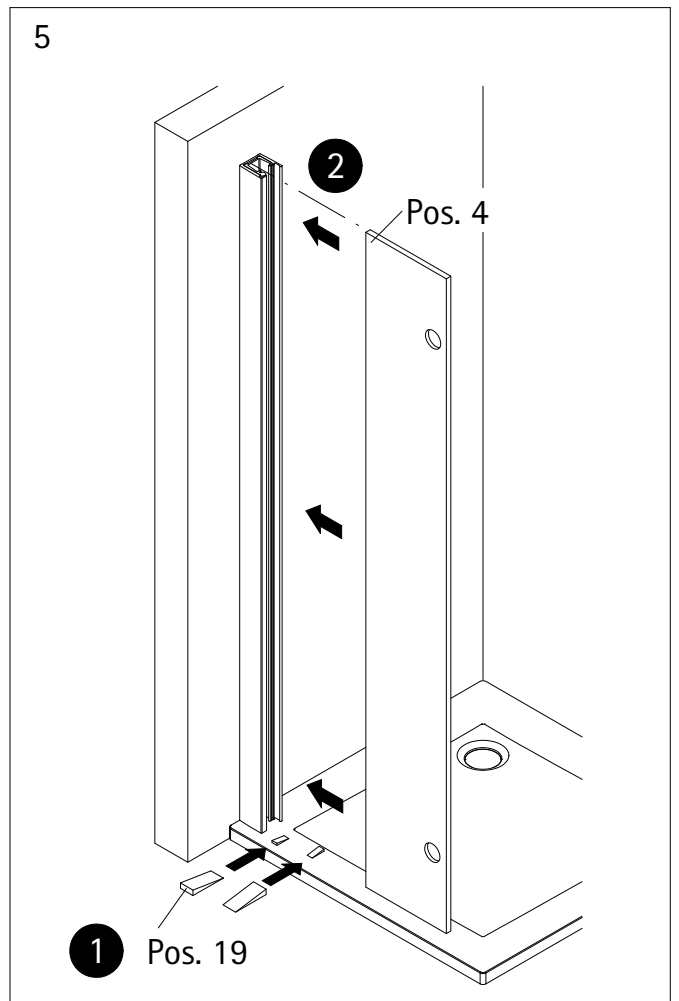
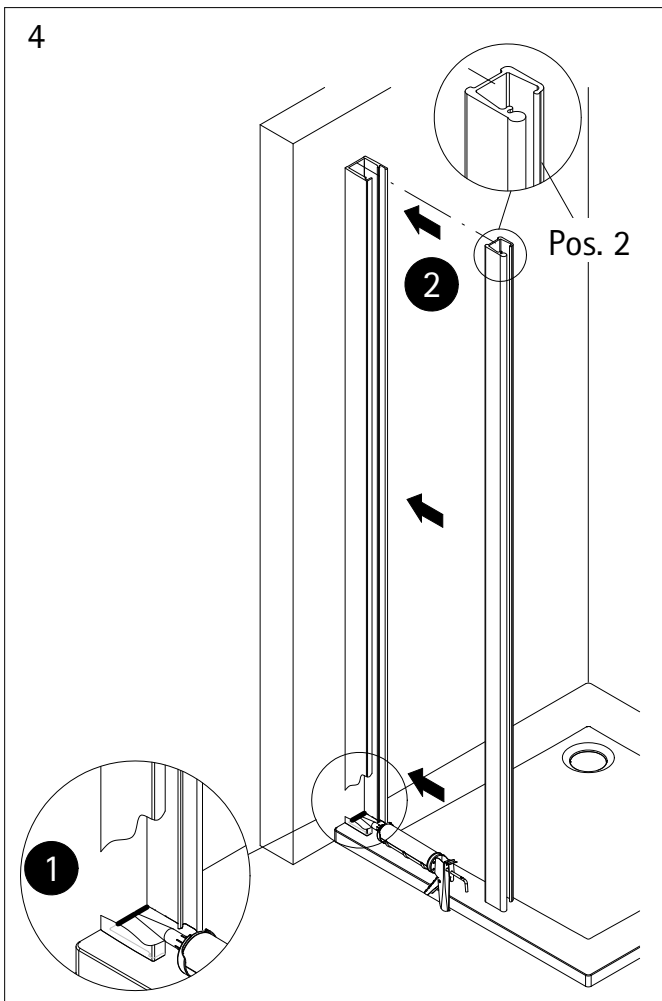
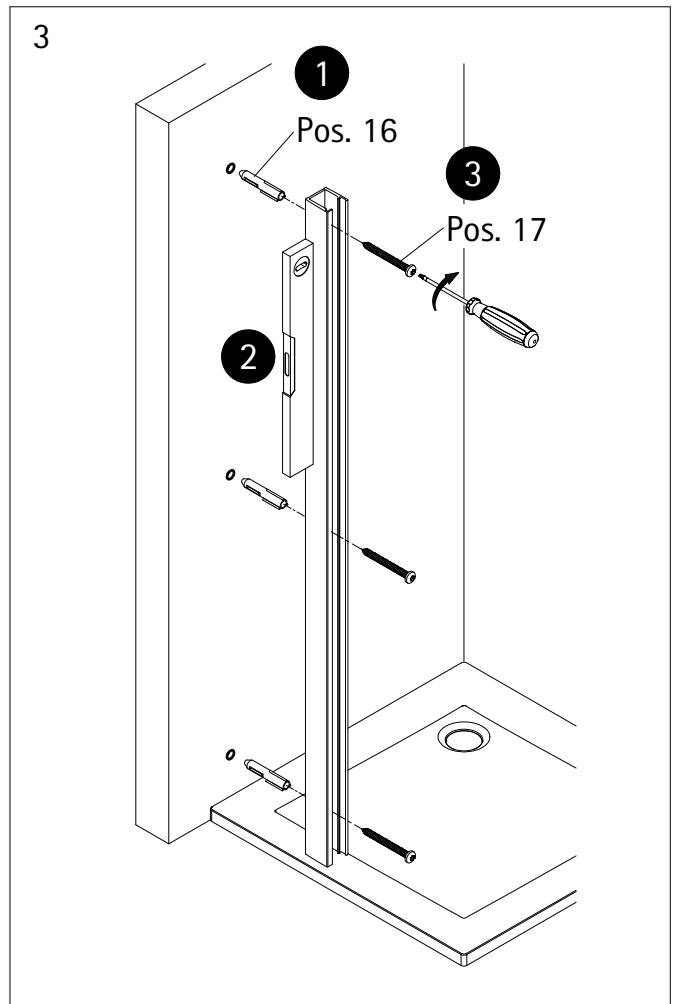
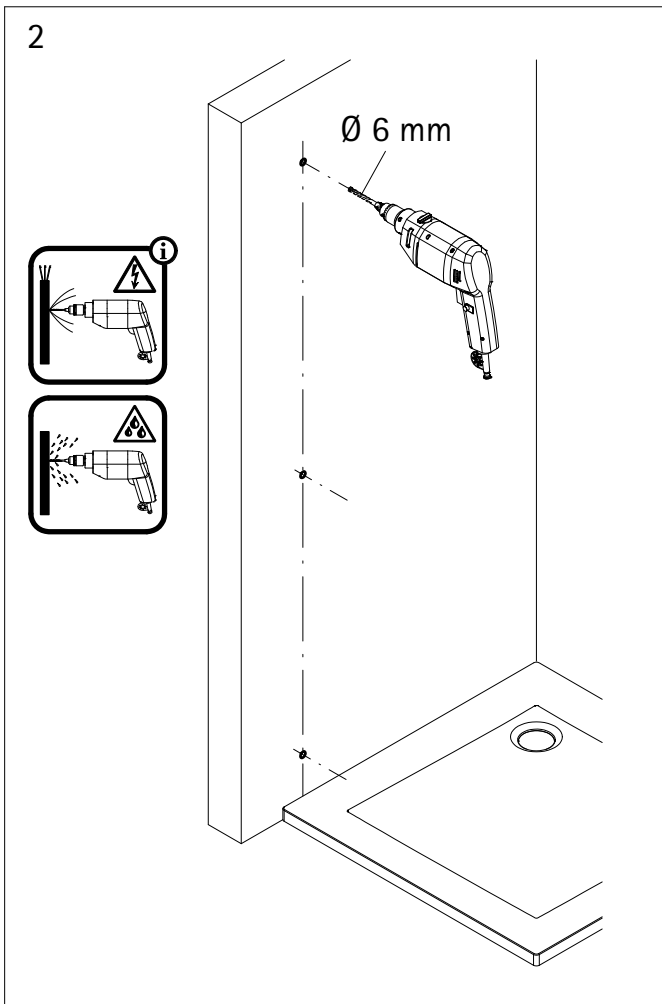



6

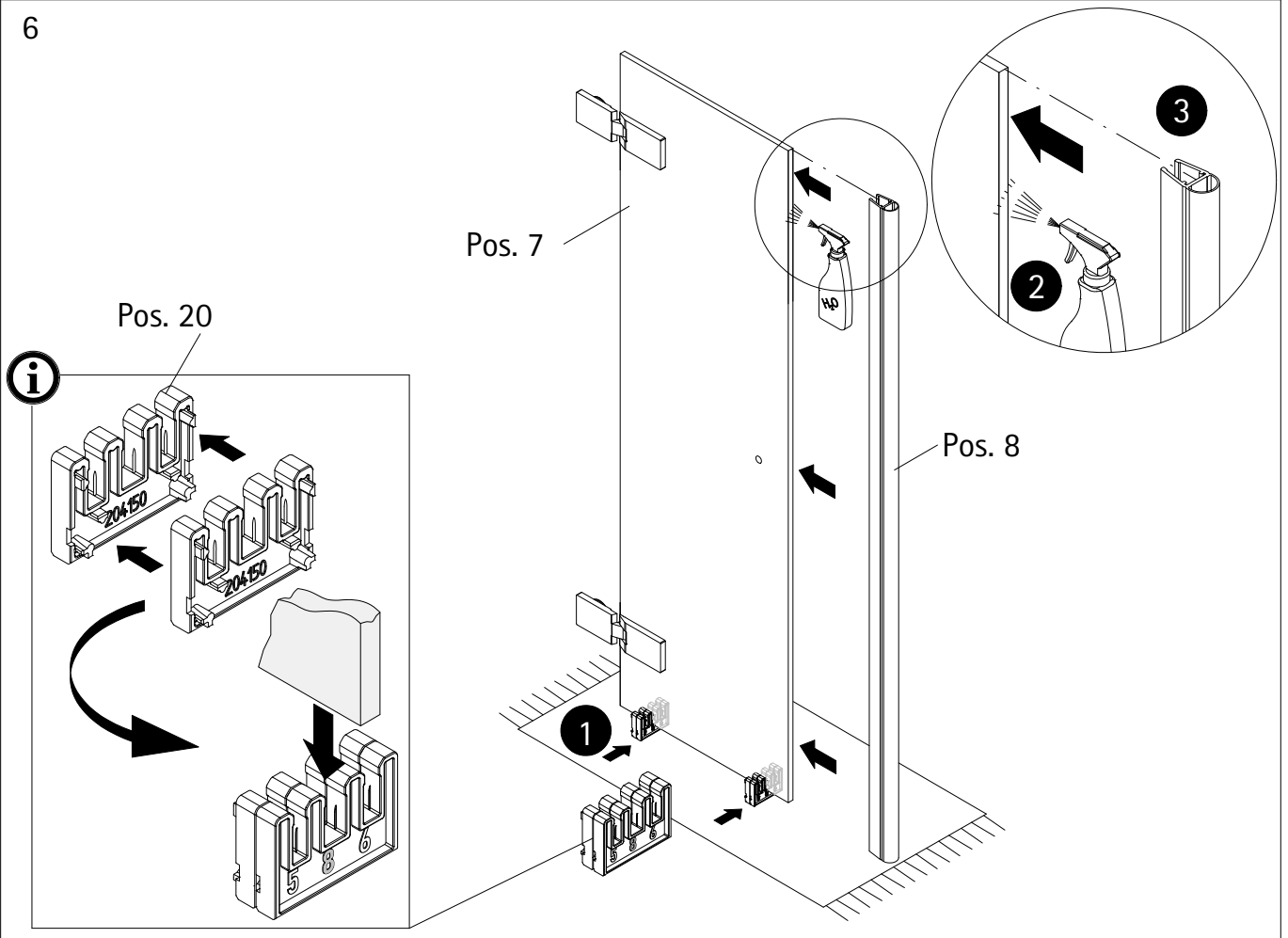

7

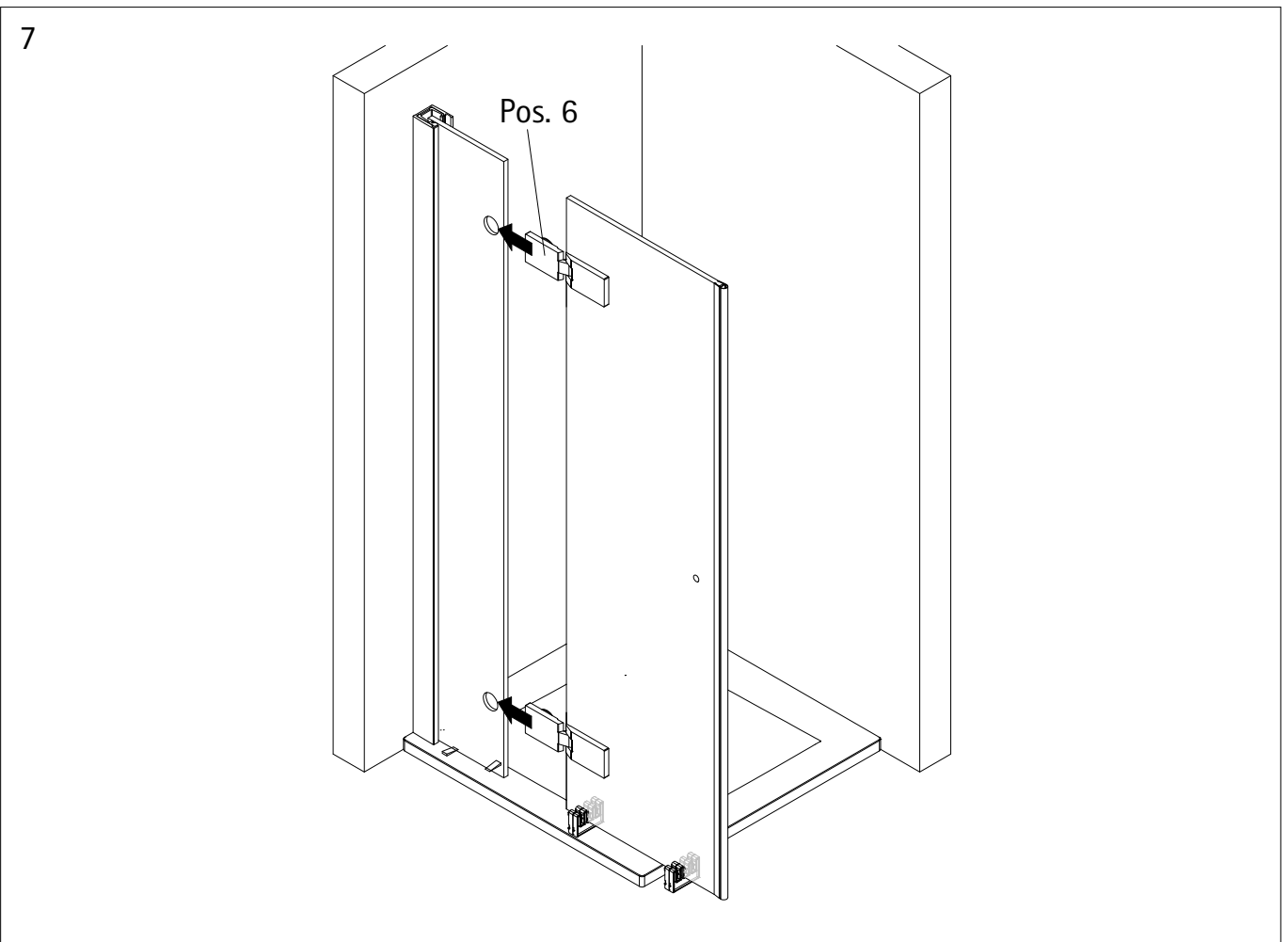

8

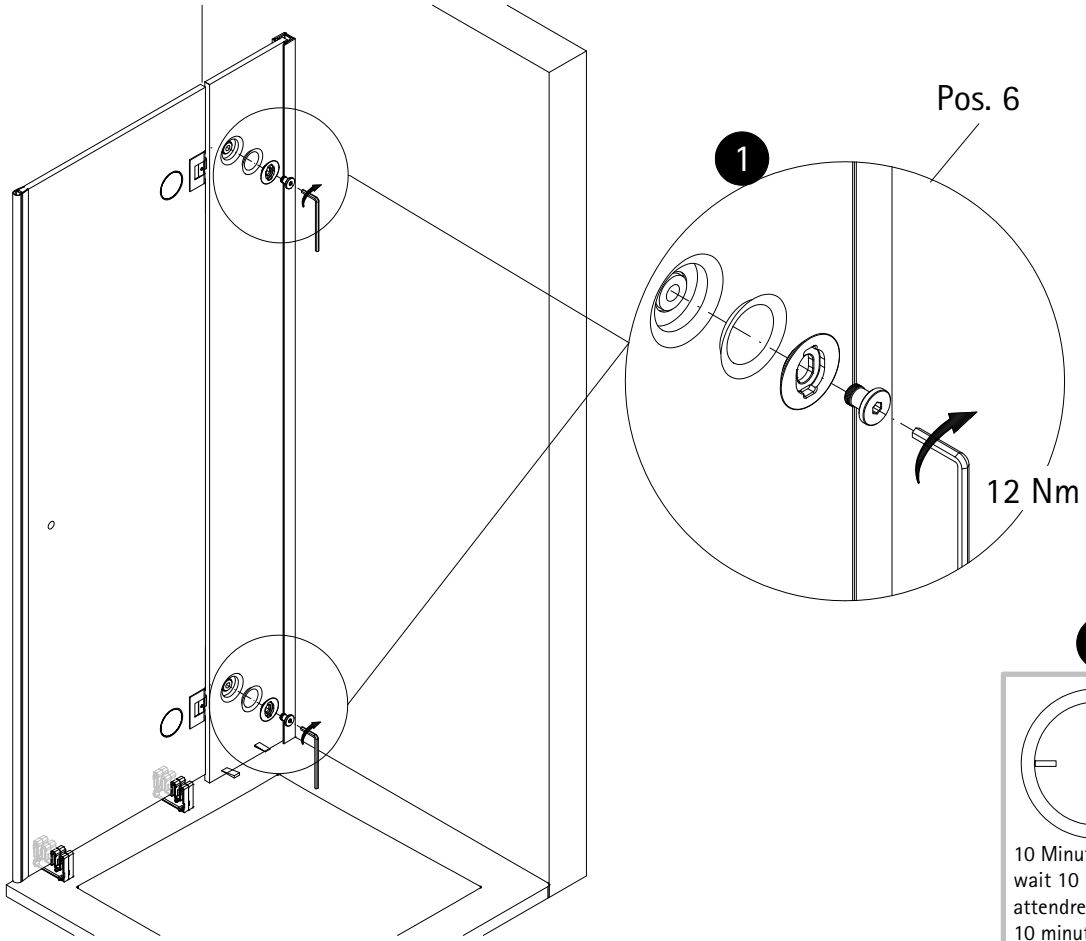

9

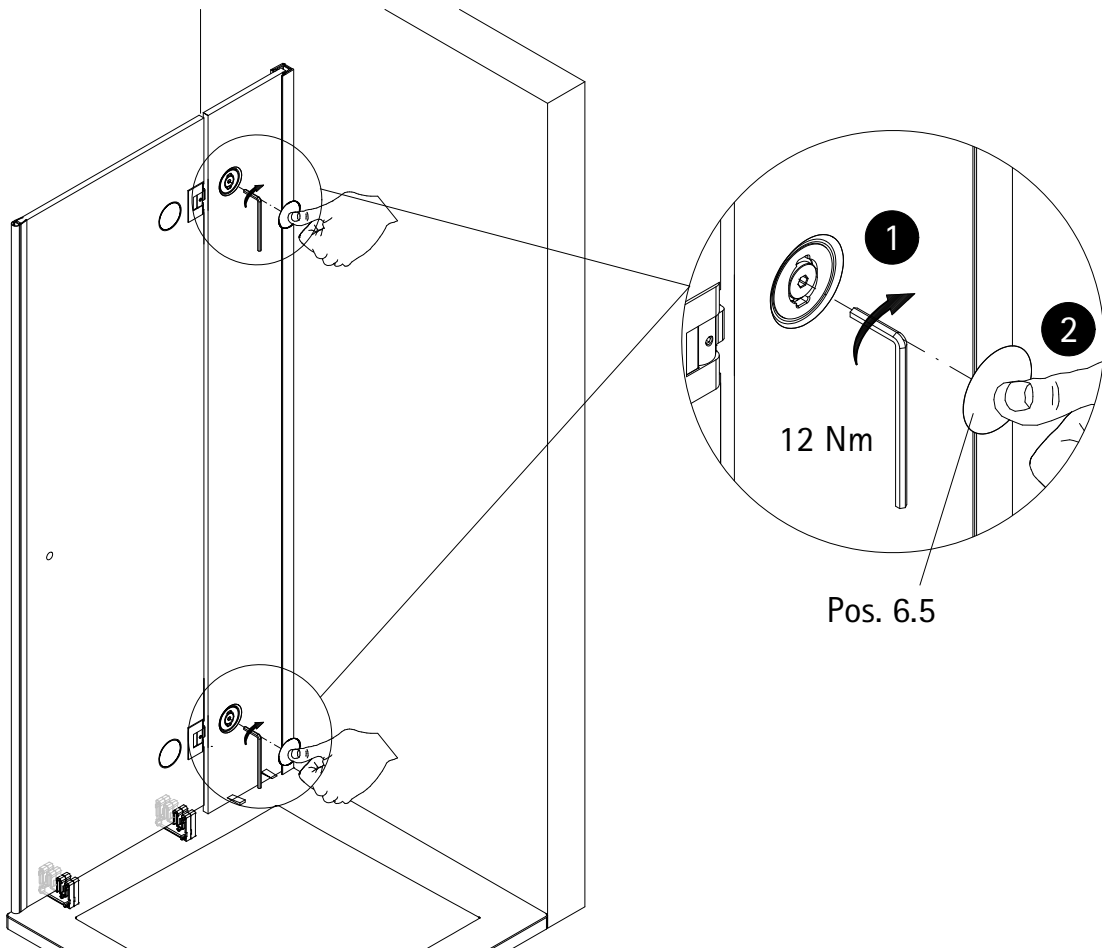

10

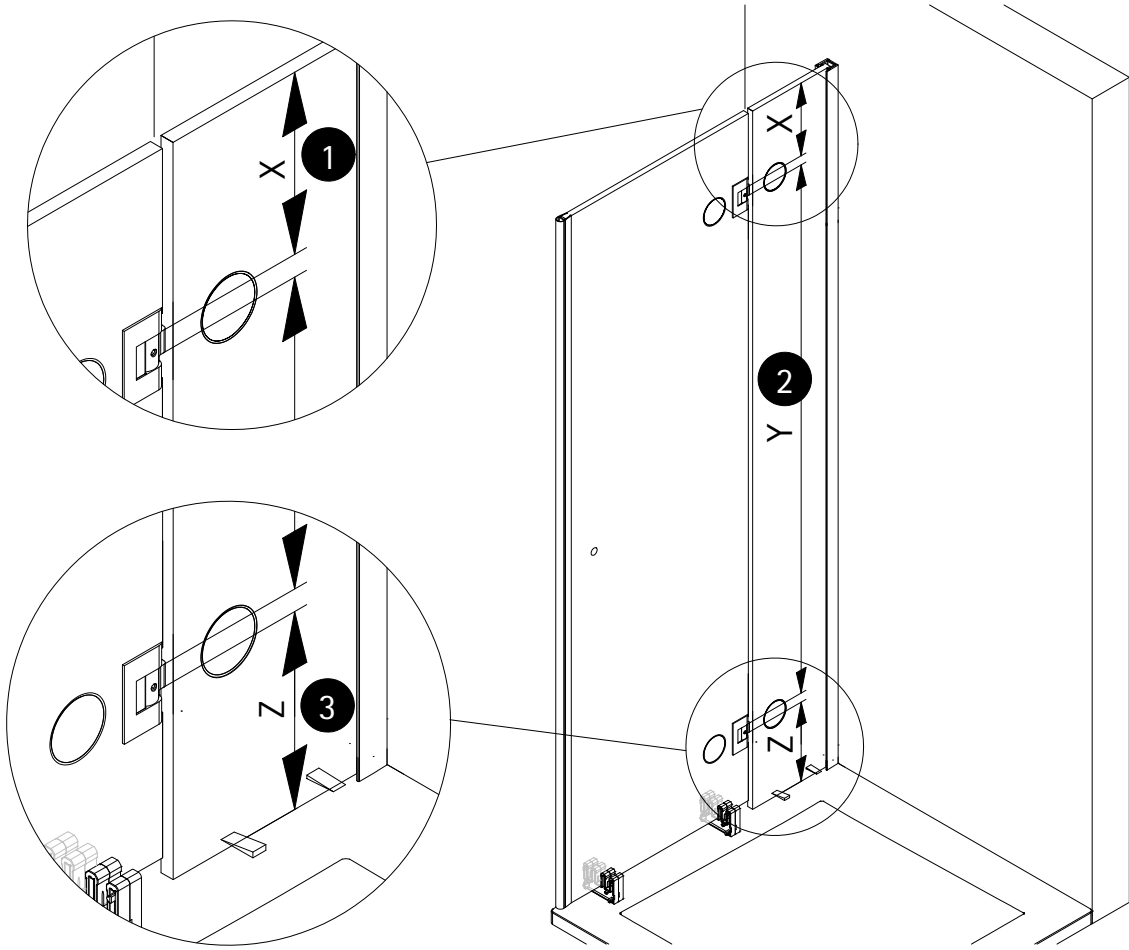

11

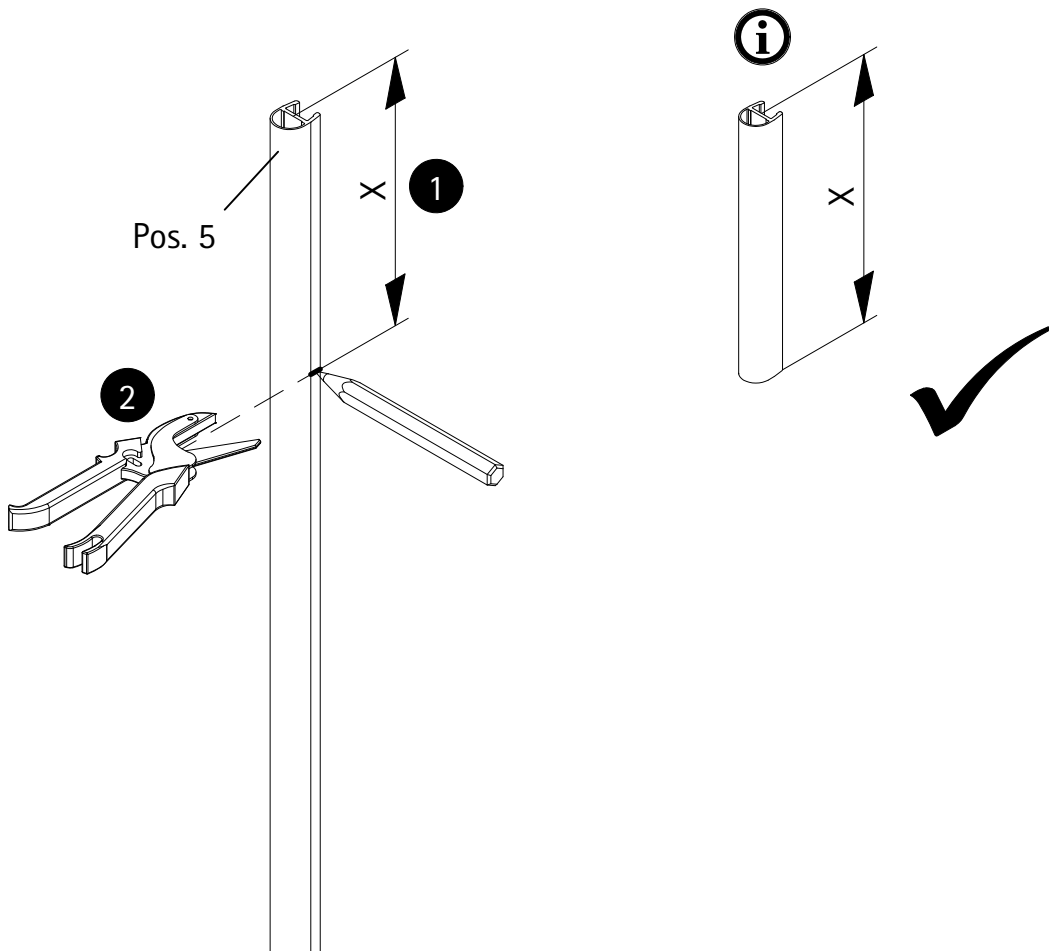

12

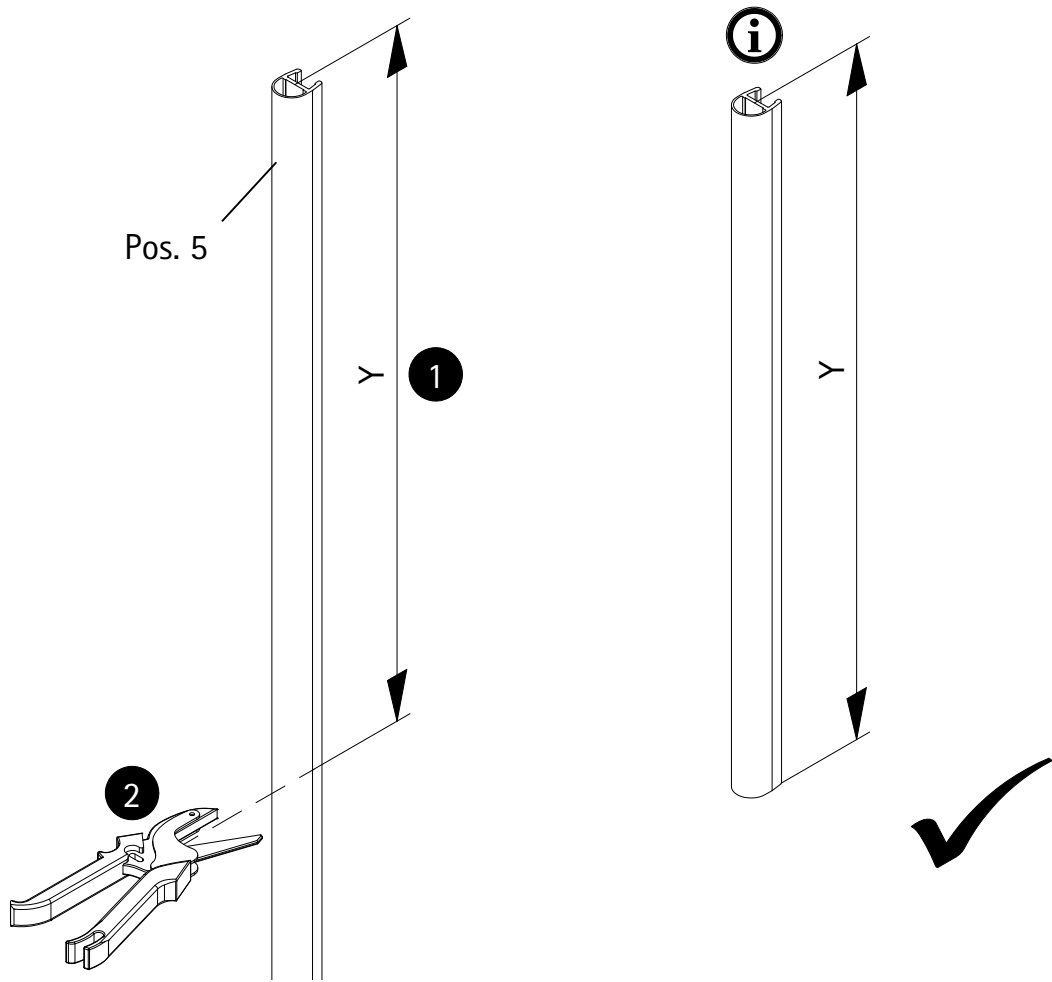

13

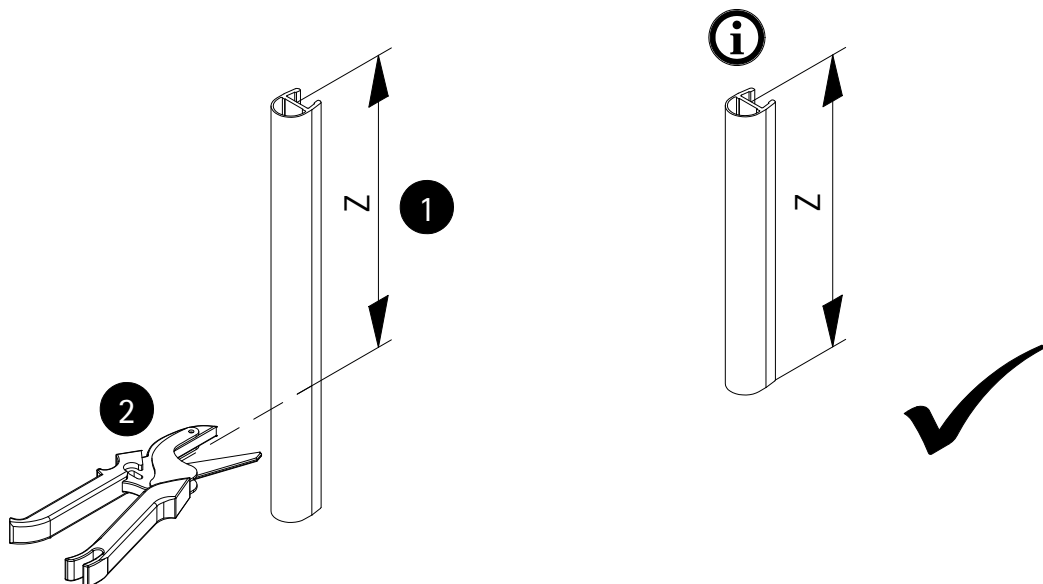

14

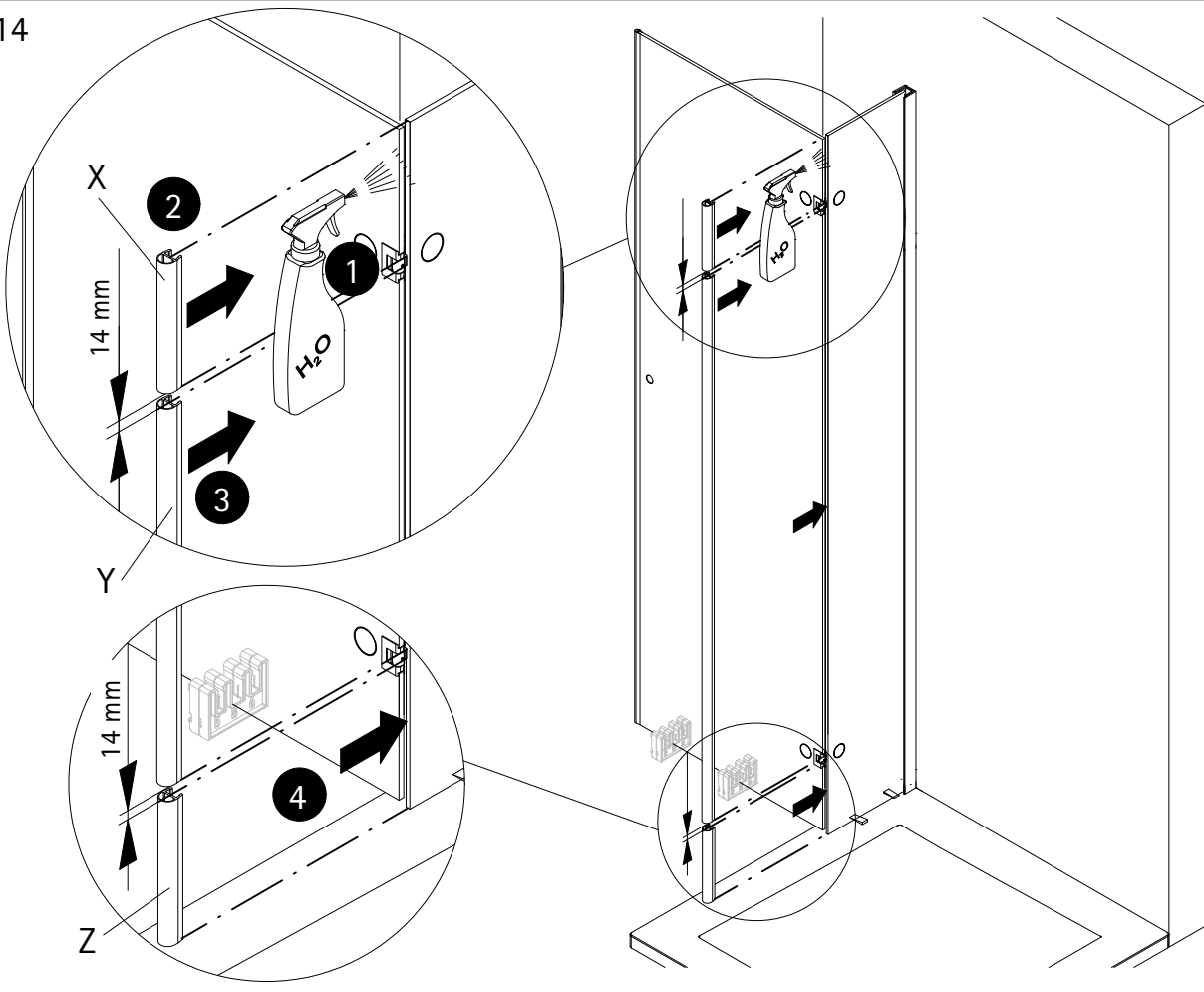

15

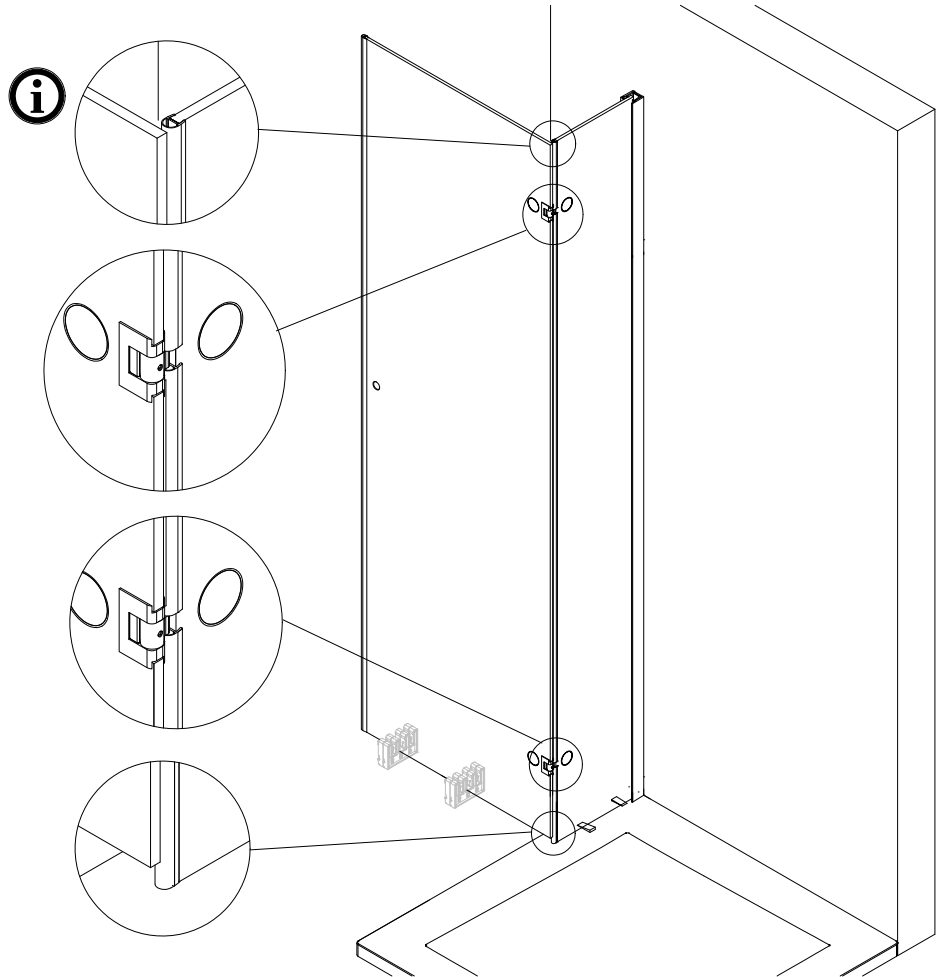

16

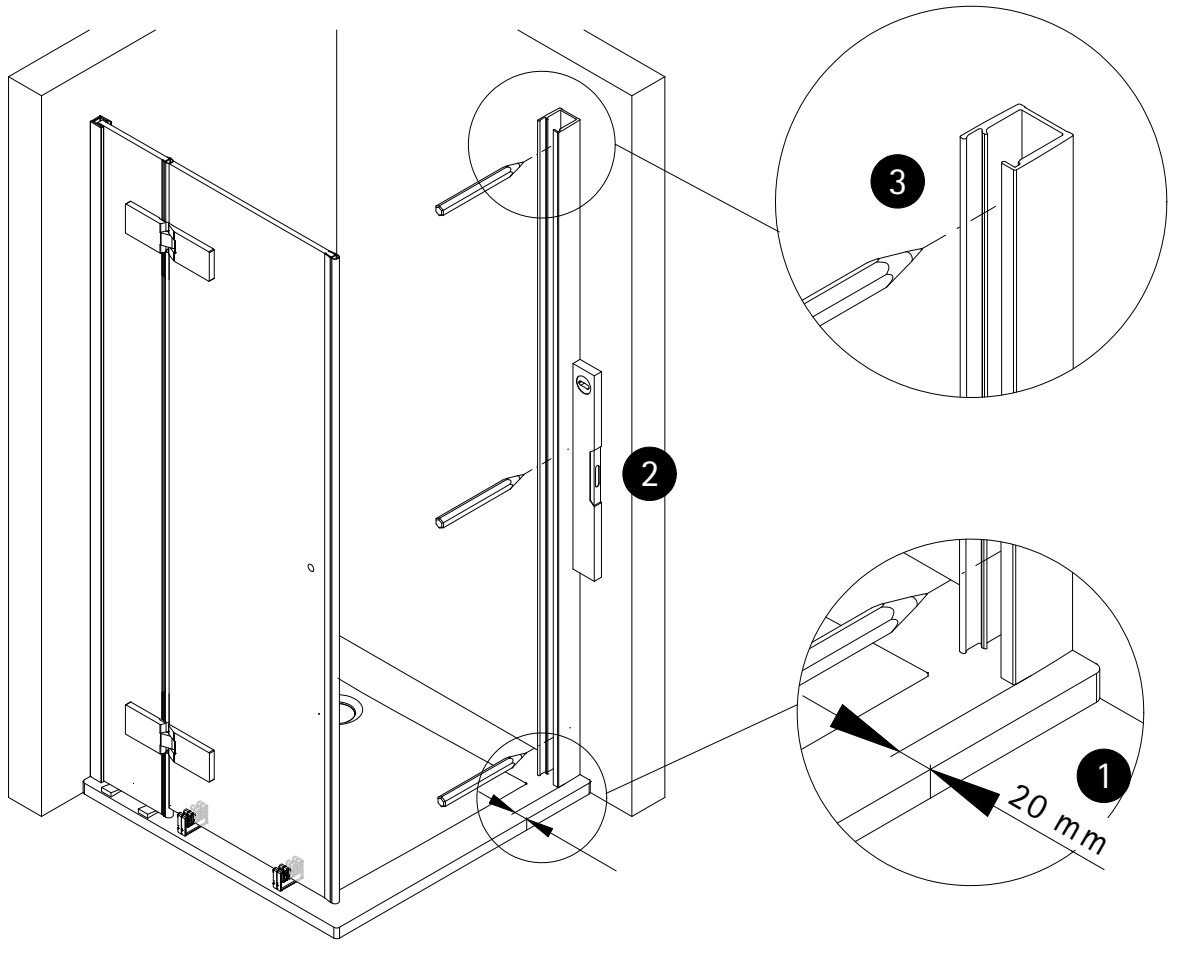

17

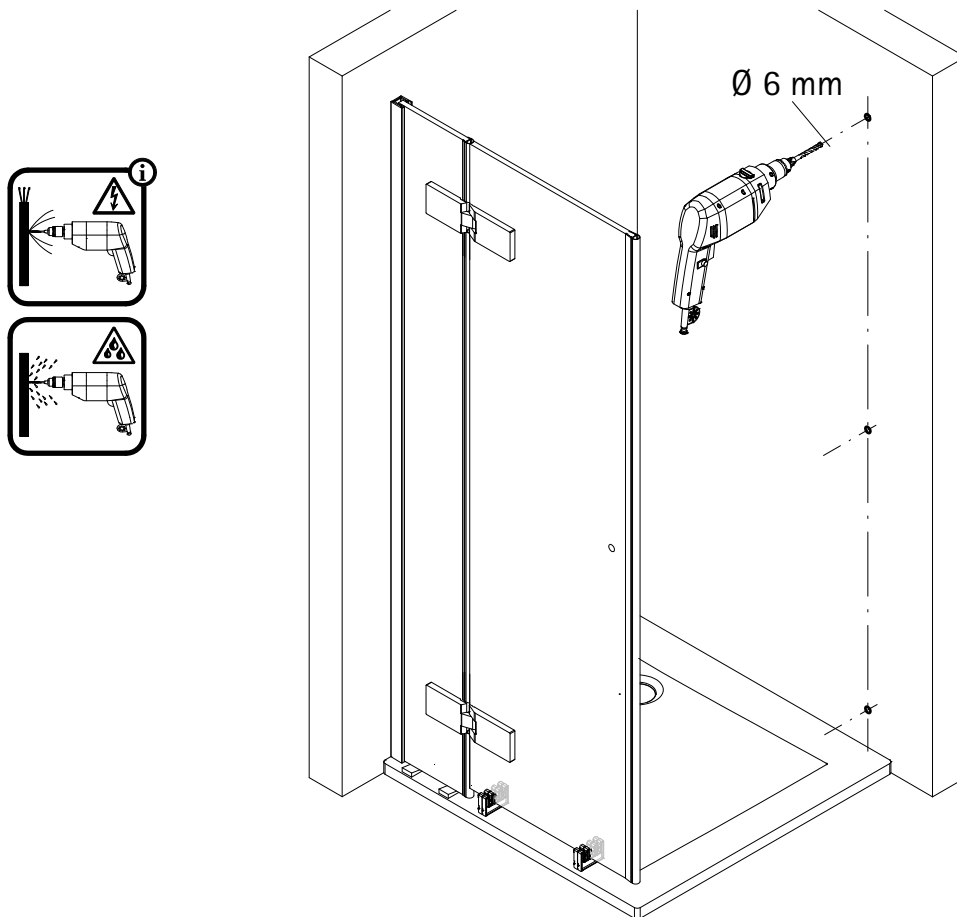

18

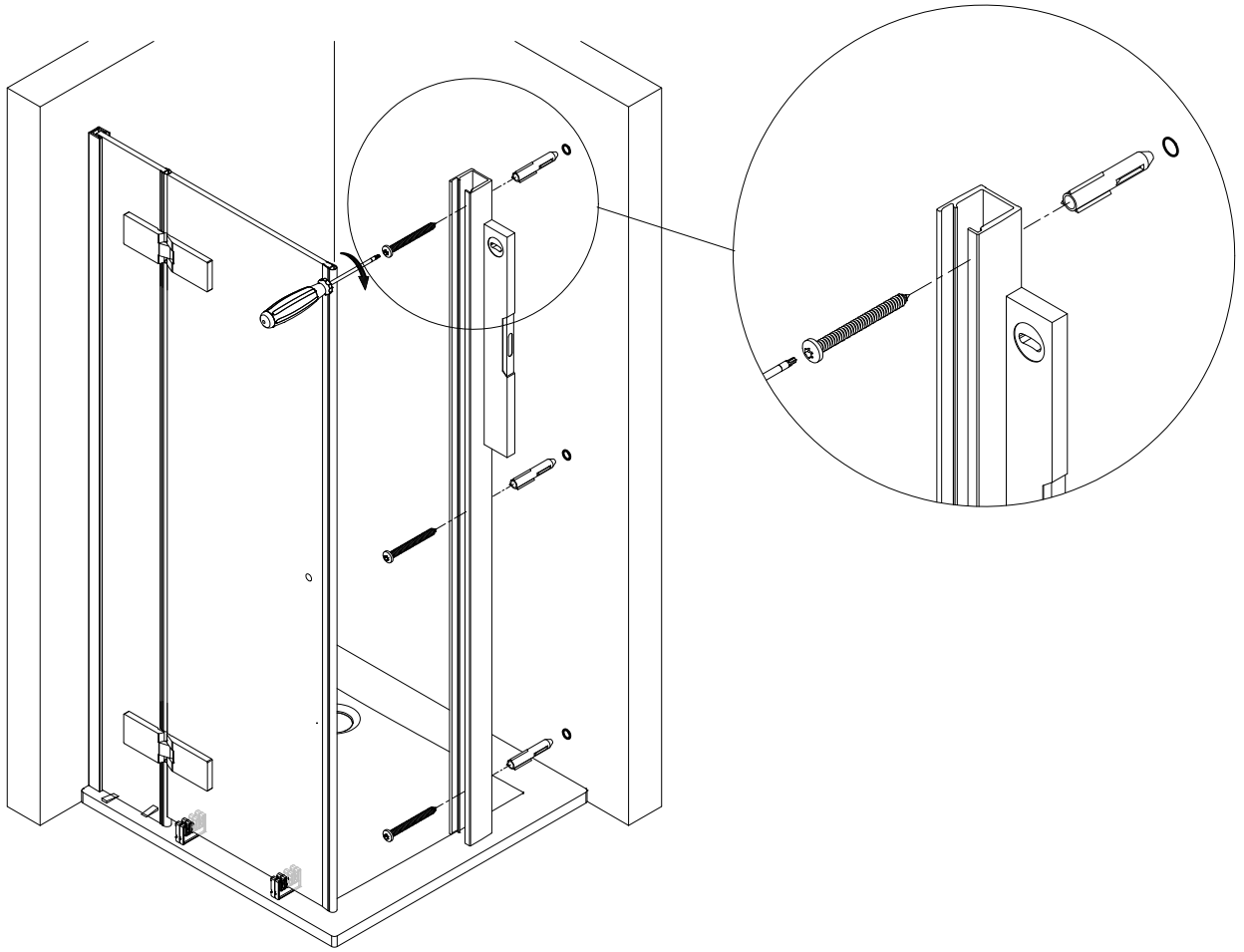

19

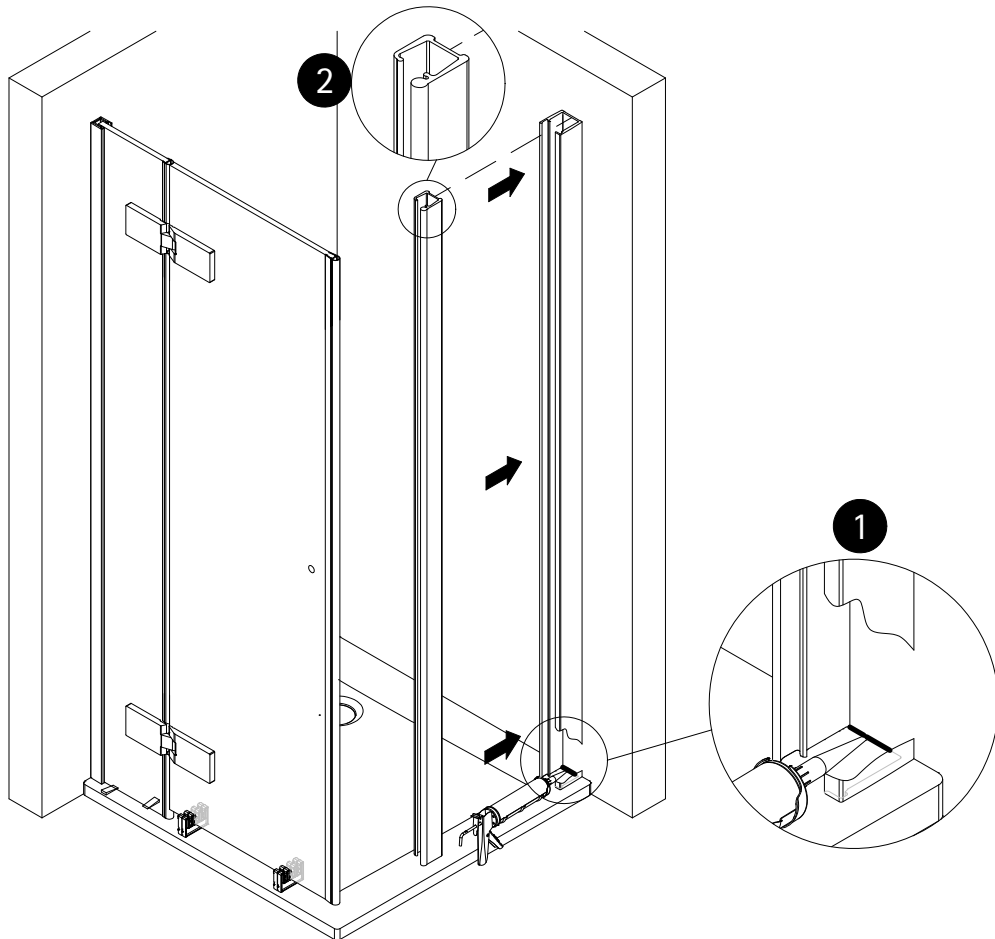

20

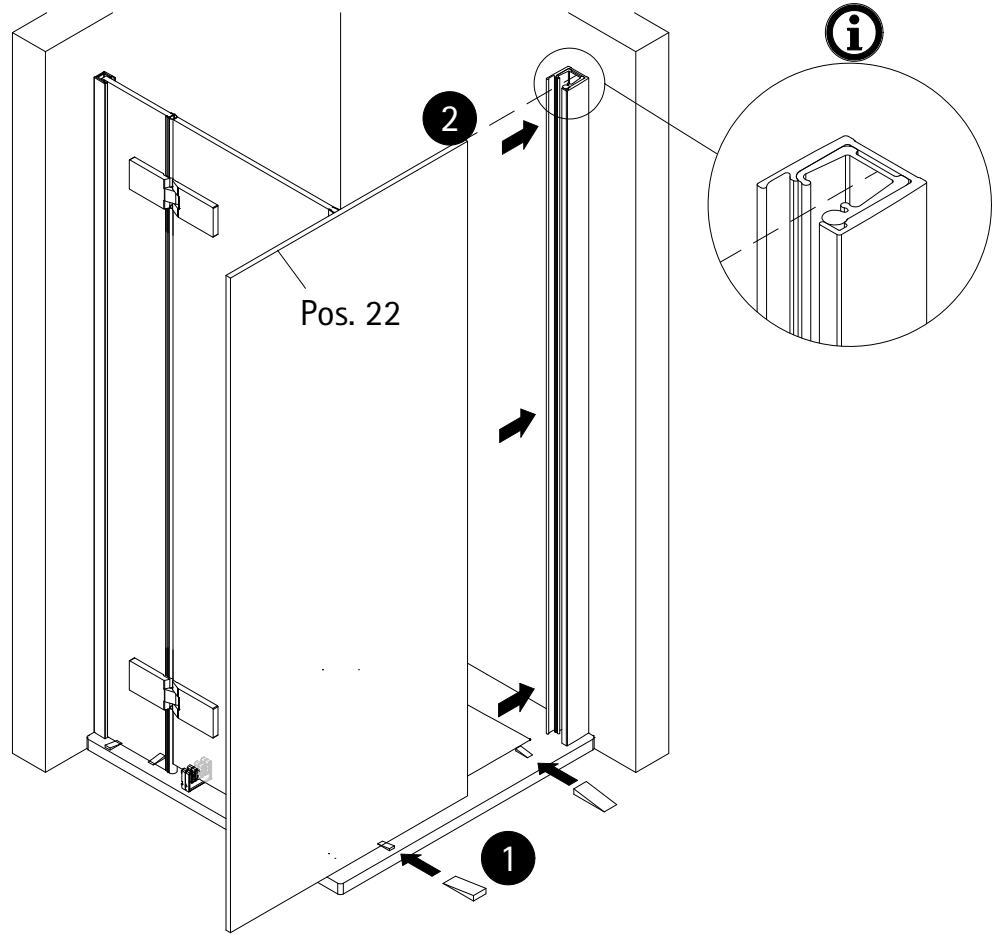

21

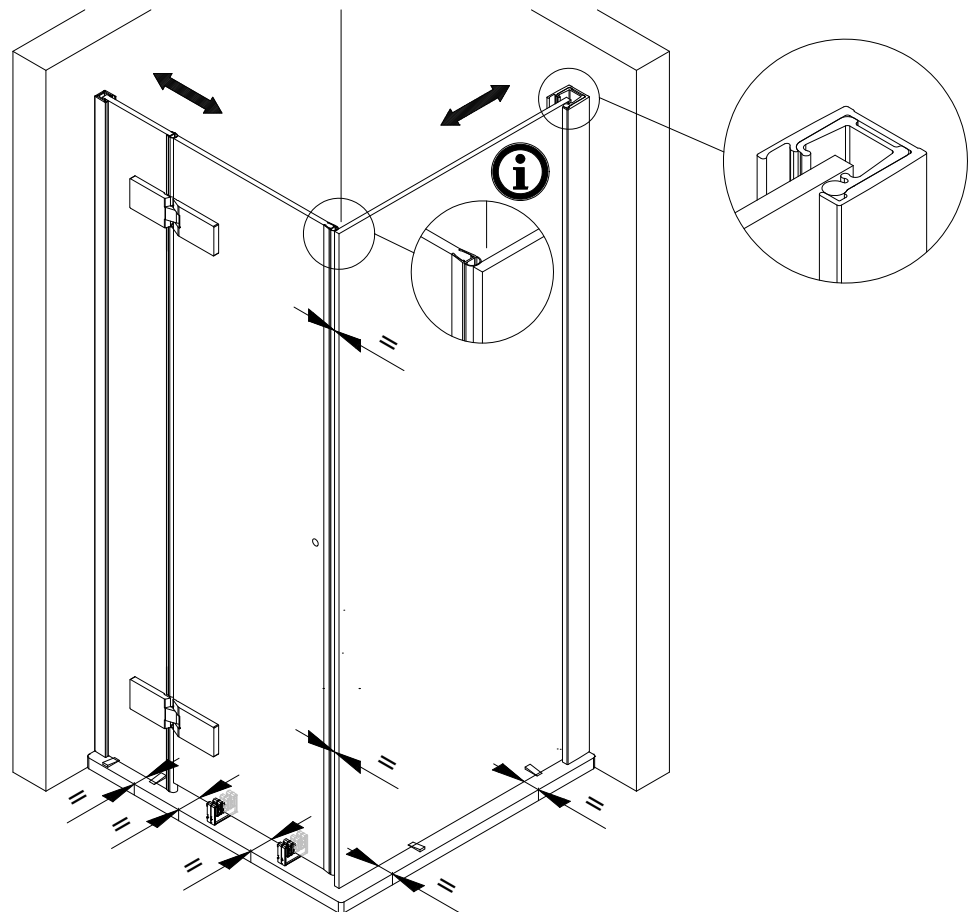



22

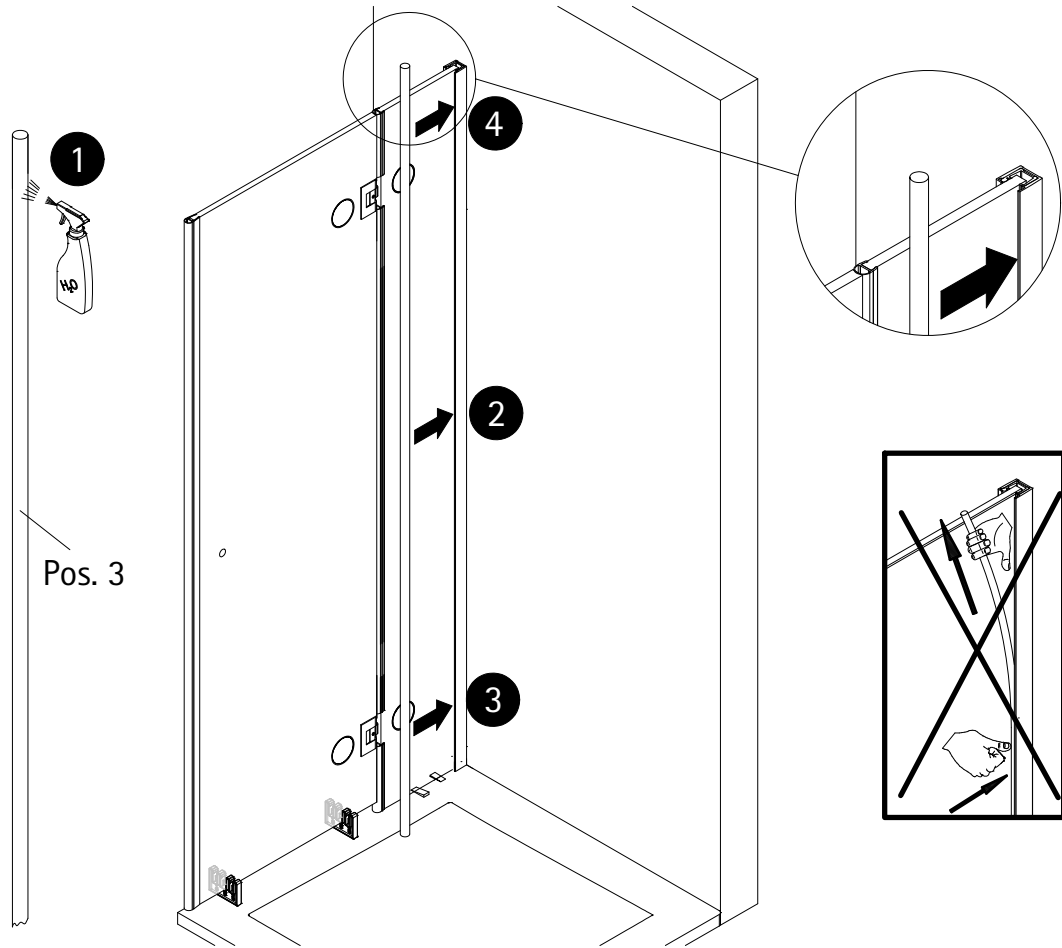

23

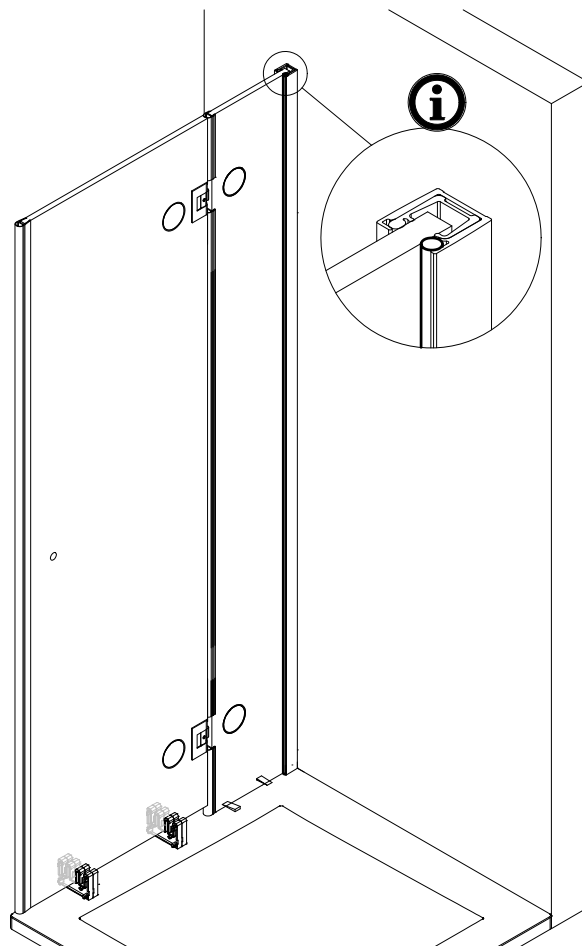

24

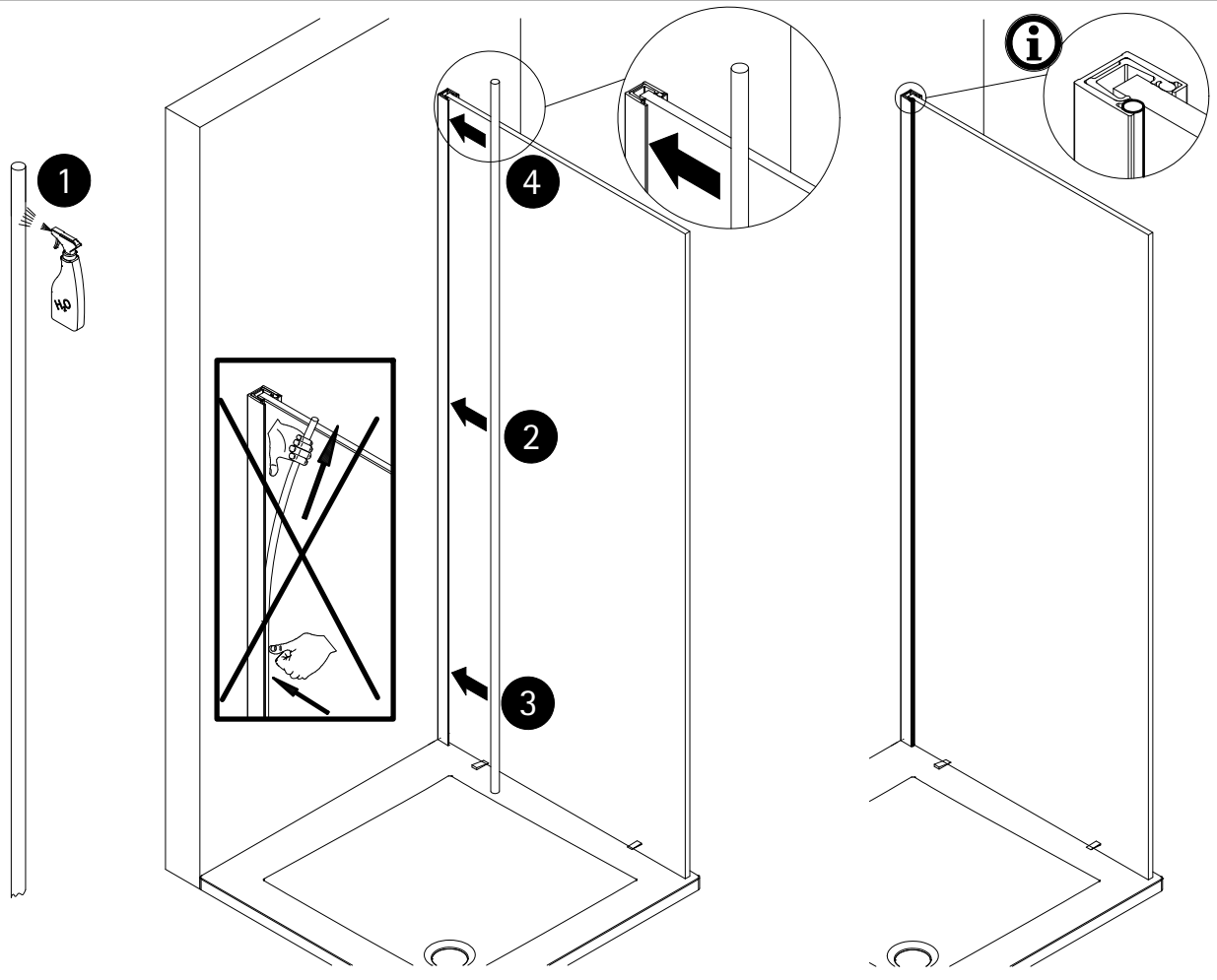

25

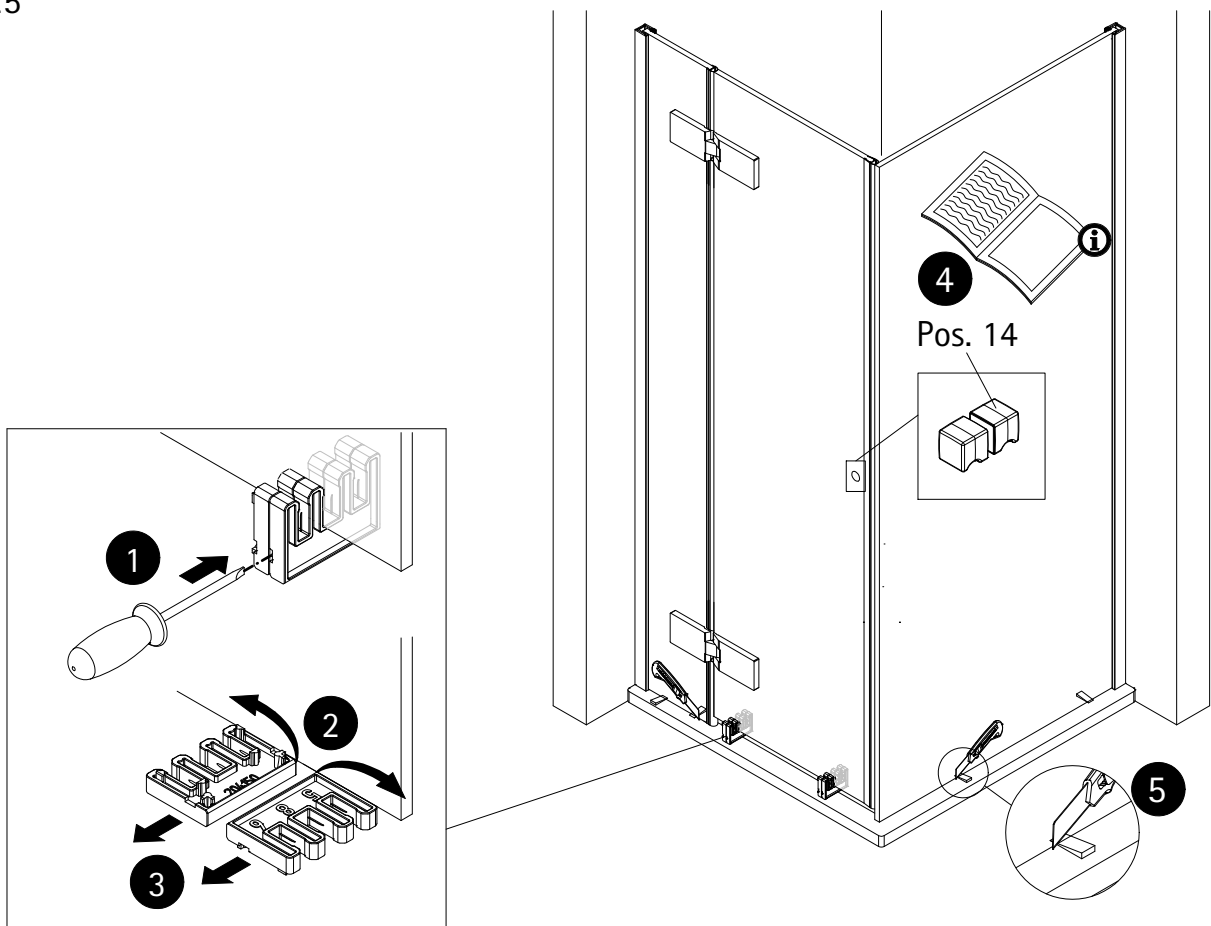

26

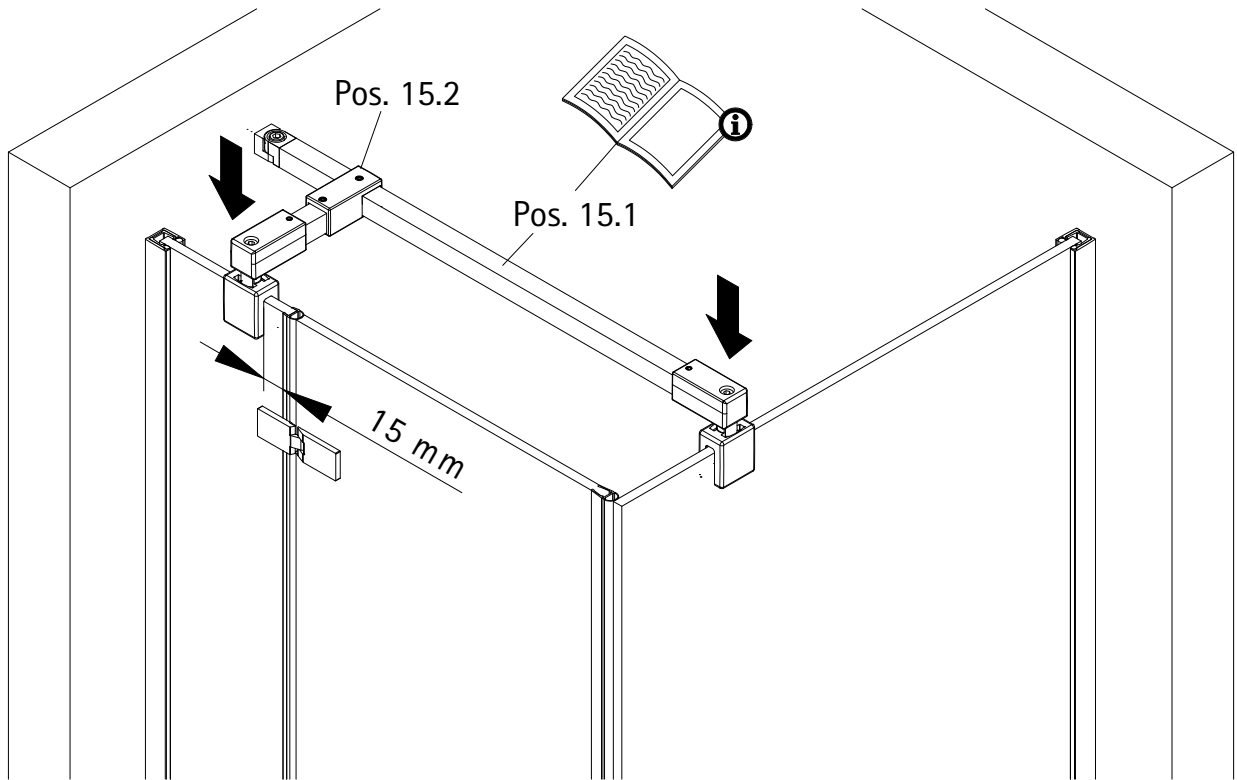

27

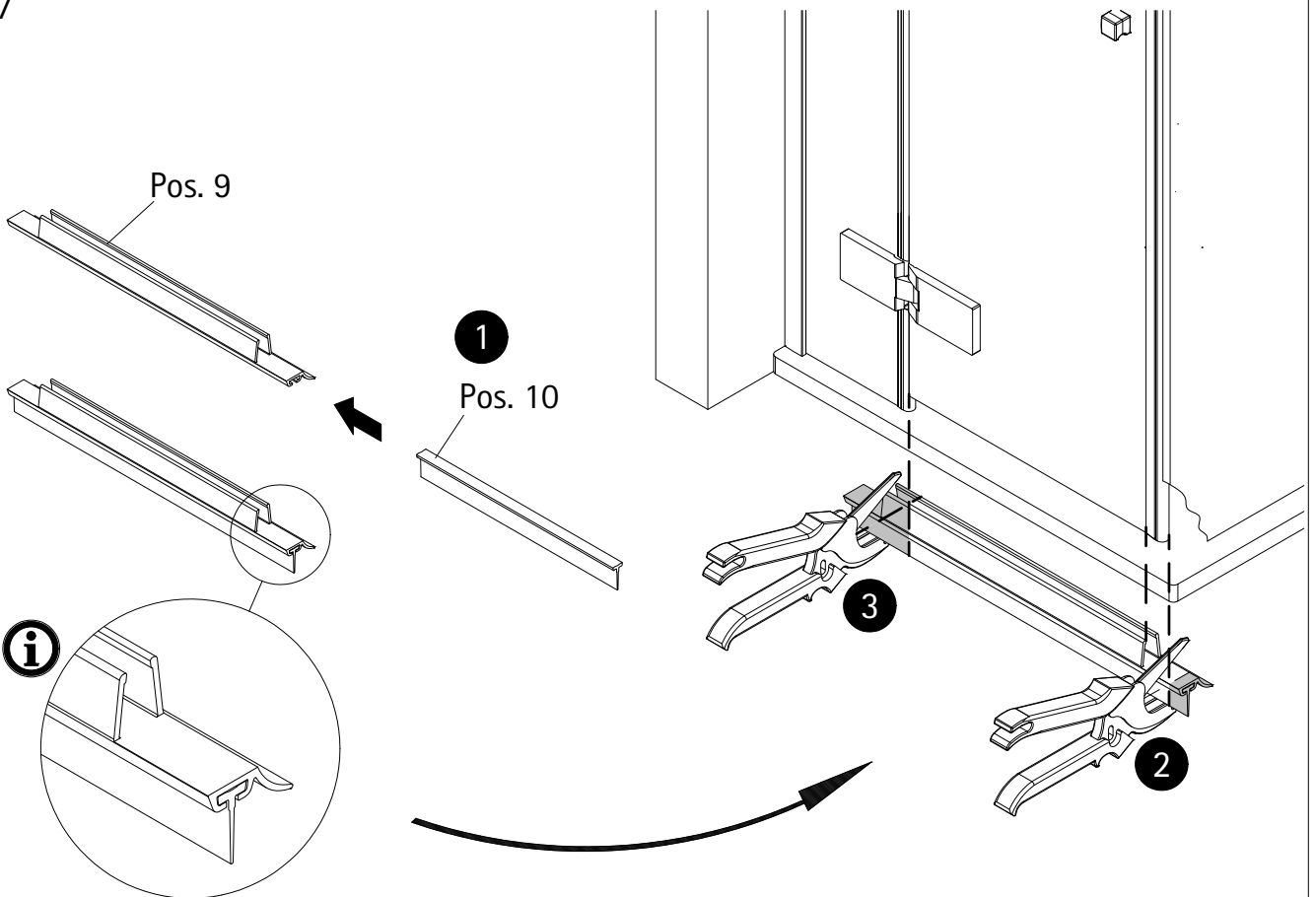

28

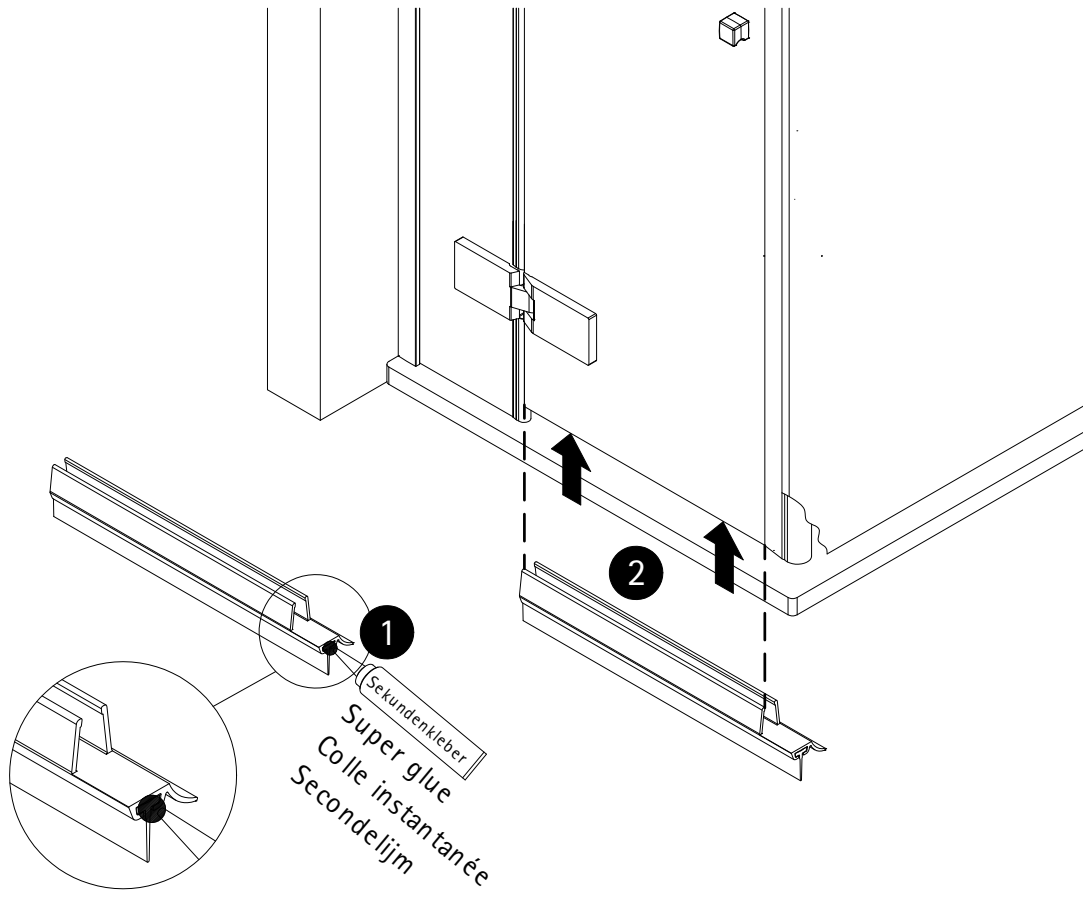

29

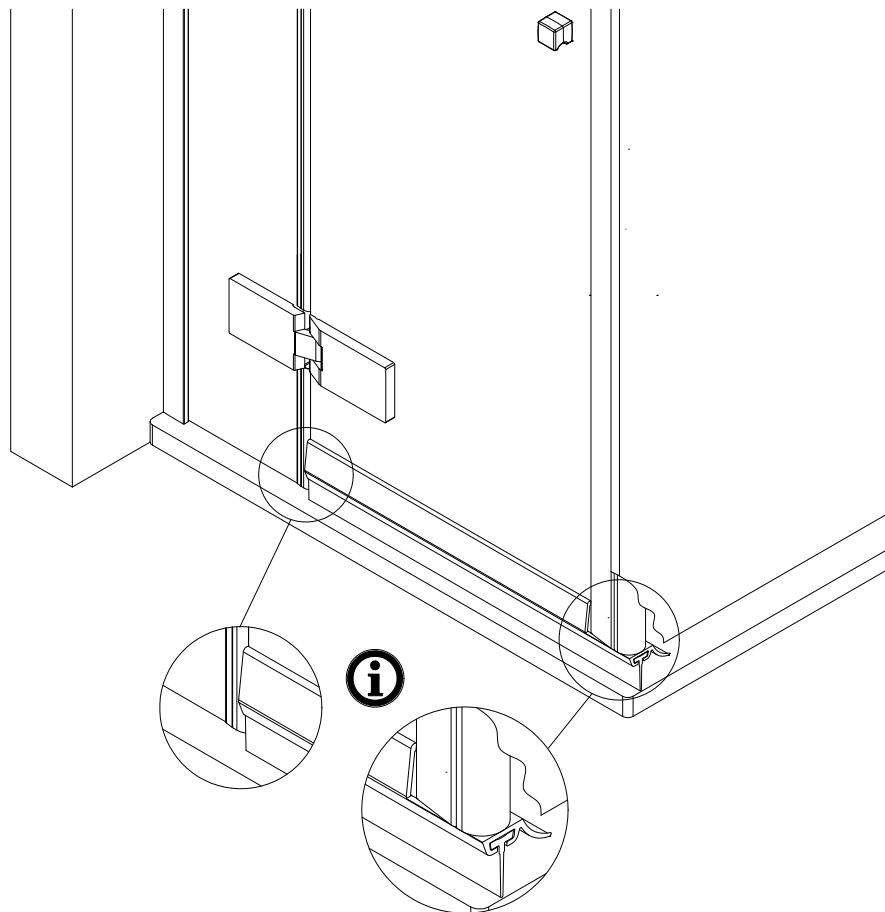

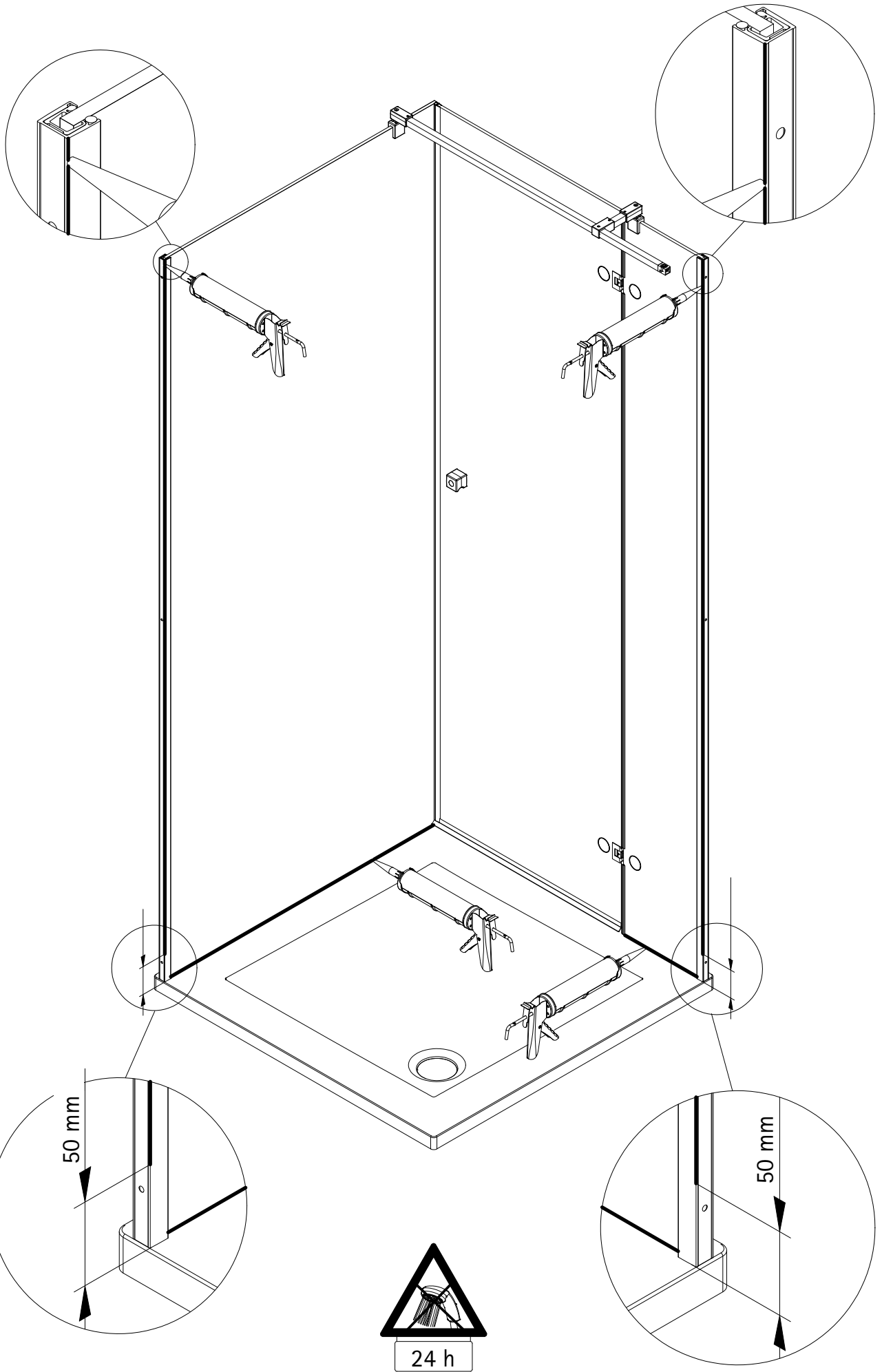

31

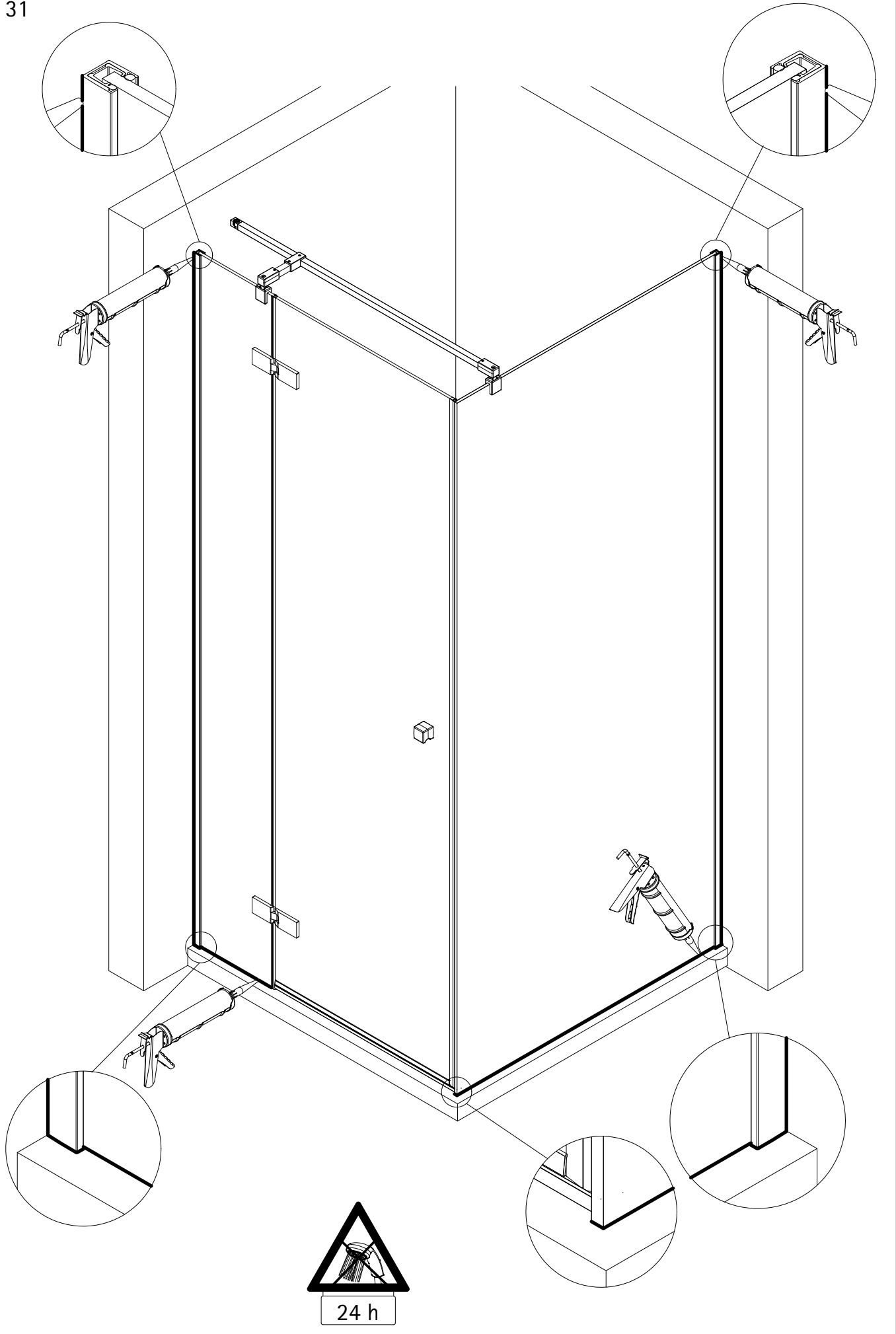

# Notizen, notes, notities

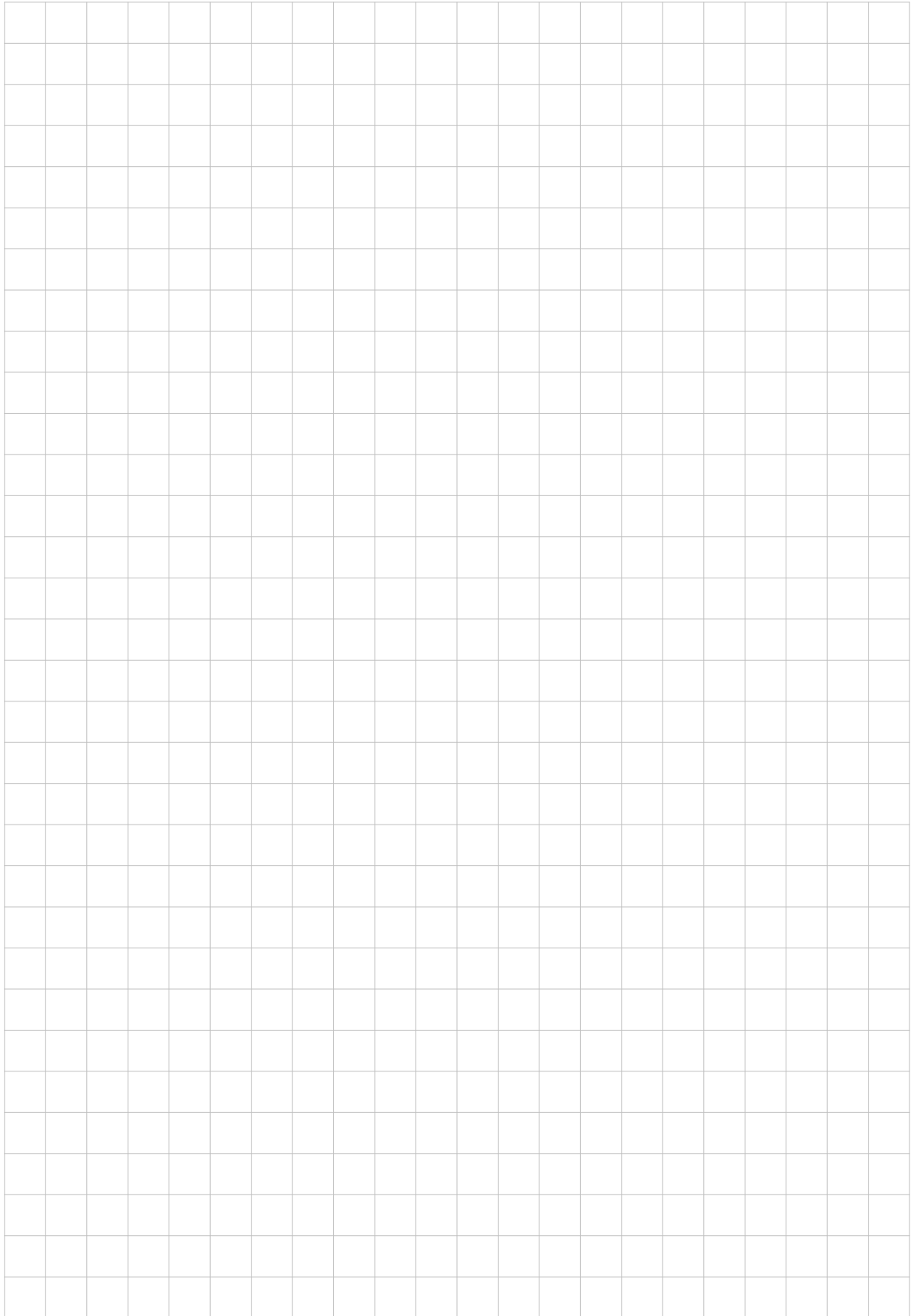

2132-5

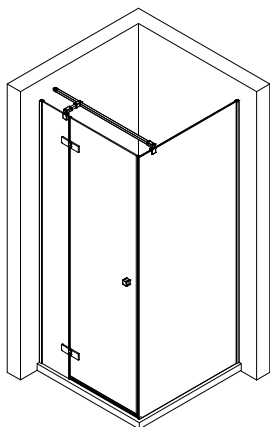

Prüfnummer / Inspection number / Numéro de contrôle / Testnummer



Ersatzteilbestellung / spare parts order  
commande de pièces détachées / Bestelling van onderdelen:  
Fax 02962 / 972-4260



Technische Hilfe / technical help / l'aide technique / technologische ondersteuning  
Telefon 02962 / 9724-0



E-Mail:  
[ersatzteile@duschservice.de](mailto:ersatzteile@duschservice.de)



Duschservice  
Zum Hohlen Morgen 22  
59939 Olsberg  
Deutschland / Germany / Allemagne / Duitsland



00008027800000000000000000